

FORESEE eMMC FEMDNN016G-58A43 Datasheet

Version: 1.3

2021.01.07

LONGSYS ELECTRONICS RESERVES THE RIGHT TO CHANGE PRODUCTS, INFORMATION AND SPECIFICATIONS WITHOUT NOTICE.

Products and specifications discussed herein are for reference purposes only. All information discussed herein is provided on an "AS IS" basis, without warranties of any kind.

This document and all information discussed herein remain the sole and exclusive property of Longsys Electronics. No license of any patent, copyright, mask work, trademark or any other intellectual property right is granted by one party to the other party under this document, by implication, estoppel or other-wise.

Longsys products are not intended for use in life support, critical care, medical, safety equipment, or similar applications where product failure could result in loss of life or personal or physical harm, or any military or defense application, or any governmental procurement to which special terms or provisions may apply.

For updates or additional information about Longsys products, contact your nearest Longsys office.

All brand names, trademarks and registered trademarks belong to their respective owners.

© 2020 Shenzhen Longsys Electronics Co., Ltd. All rights reserved.

Revision History:

Rev.	Date	Changes	Remark
0.1	2020/03/25	Basic spec and architecture	Target
1.0	2020/05/11	Content modification	Preliminary
1.1	2020/06/16	1. Product List 2. Performance 3. Partition configuration 4. Processing Guide	Preliminary
1.2	2020/09/24	1.Format adjustment 2.User Size 3.Performance	Preliminary
1.3	2021/01/07	1.SEC_count	Preliminary

CONTENTS

1. Introduction	1
2. Product List	1
3. Features	1
4. Functional Description.....	2
5. Product Specifications.....	3
5.1 Performance	3
5.2 Power Consumption	3
6. Pin Assignments.....	4
6.1 Ball Array view	4
6.2 Ball Array view	4
7. Usage Overview	6
7.1 General description.....	6
7.2 Partition Management	6
7.3 Automatic Sleep Mode.....	8
7.4 Sleep (CMD5).....	8
7.5 H/W Reset operation.....	9
7.6 High-speed mode selection	9
7.7 Bus width selection	9
7.8 Partition configuration	9
7.9 CID register	9
7.10 CSD register	10
7.11 Extended CSD register	11
7.12 OCR Register.....	21
7.13 Field firmware update(FFU).....	22
7.14 S.M.A.R.T. Health Report	23
8. Package Dimension	24
9 Connection Guide.....	24
9.1 Schematic Diagram.....	24
10. Processing Guide.....	25

1. Introduction

FORESEE eMMC is an embedded storage solution designed in the BGA package. The FORESEE eMMC consists of NAND flash and eMMC controller. The controller could manage the interface protocols, wear-leveling, bad block management and ECC.

FORESEE eMMC has high performance at a competitive cost, high quality and low power consumption, and eMMC is compatible with JEDEC standard eMMC 5.1 specifications.

2. Product List

Density	Part Number	Capacity (MB)	Capacity (bytes)	User Density(%)	Package Size(mm)	Package Type
16GB	FEMDNN016G-58A43	14940	15,665,725,440	91	11.5x13x1.0	153FBGA

3. Features

- **eMMC5.1 specification compatibility**
(Backward compatible to eMMC4.41/4.5/5.0)
- **Bus mode**
 - Data bus width: 1 bit (default), 4 bits, 8 bits
 - Data transfer rate: up to 400MB/s (HS400)
 - MMC I/F Clock frequency : 0~200MHz
- **Operating voltage range**
 - Vcc(NAND) : 2.7 - 3.6V
 - Vccq(Controller) : 1.7 - 1.95V / 2.7 - 3.6V
- **Temperature**
 - Operation (-25°C ~ +85°C)
 - Storage without operation (-40°C ~ +85°C)
- **Sudden-Power-Loss safeguard**
- **Hardware ECC engine**
- **Unique firmware backup mechanism**
- **Global-wear-leveling**
- **Supported features.**
 - HS400, HS200
 - Partitioning, RPMB
 - Boot feature, boot partition
 - HW Reset/SW Reset
 - Discard, Trim, Erase, Sanitize
 - Background operations, HPI
 - Enhanced reliable write
 - S.M.A.R.T. Health Report
 - FFU
 - Sleep / awake
- **Others**
 - Compliance with the RoHS Directive

4. Functional Description

FORESEE eMMC with powerful L2P (Logical to Physical) NAND Flash management algorithm provides unique functions:

- Host independence from details of operating NAND flash
- Internal ECC to correct defect in NAND flash
- Sudden-Power-Loss safeguard

To prevent from data loss, a mechanism named Sudden-Power-Loss safeguard is added in the eMMC. In the case of sudden power-failure, the eMMC would work properly after power cycling.

- Global-wear-leveling

To achieve the best stability and device endurance, this eMMC equips the Global Wear Leveling algorithm. It ensures that not only normal area, but also the frequently accessed area, such as FAT, would be programmed and erased evenly.

- IDA(Initial Data Acceleration)

The eMMC prevents the pre-burned data from data-loss with IDA, in case of our customer had pre-burned data to eMMC, before the eMMC being SMT.

- Cache

The eMMC enhanced the data written performance with Cache, with which our customer would get more endurance and reliability.

5. Product Specifications

5.1 Performance

Density	Read	Write	Turbo Write(FBA)
16GB	230MB/s	32MB/s	Up to 119MB/s

- Test Condition: Bus width x8, 200MHz DDR, 512KB data transfer, w/o file system overhead, measured on internal board
- Test tool: uBOOT (Without O/S)
- Test tool: CrystalDiskMark 6.0.0
- Test area: 1GB

5.2 Power Consumption

5.2.1 Active power consumption during operation

Density	Icc	Iccq
16GB	70mA	100mA

- Power Measurement conditions: Bus configuration =x8 @200MHz DDR, 25°C.
- Vcc:3.3V & Vccq: 1.8V.
- The measurement for max RMS current is the average RMS current consumption over a period of 100ms.

5.2.2 Low power mode (stand-by)

Density	Icc	Iccq
16GB	100uA	150uA

- Power Measurement conditions: Bus configuration =x8 @200MHz DDR, 25°C.
- Vcc:3.3V & Vccq: 1.8V.
- Standby: Nand Vcc & Controller Vccq power supply is switched on.
- The measurement for max RMS current is the average RMS current consumption over a period of 100ms.

5.2.3 Low power mode (sleep)

Density	Icc	Iccq
16GB	0	100uA

- Power Measurement conditions: Bus configuration =x8 @200MHz DDR, 25°C.
- Vcc:3.3V & Vccq: 1.8V.
- Sleep: Nand Vcc power supply is switched off(Controller Vccq on)
- The measurement for max RMS current is the average RMS current consumption over a period of 100ms.

6. Pin Assignments

6.1 Ball Array view

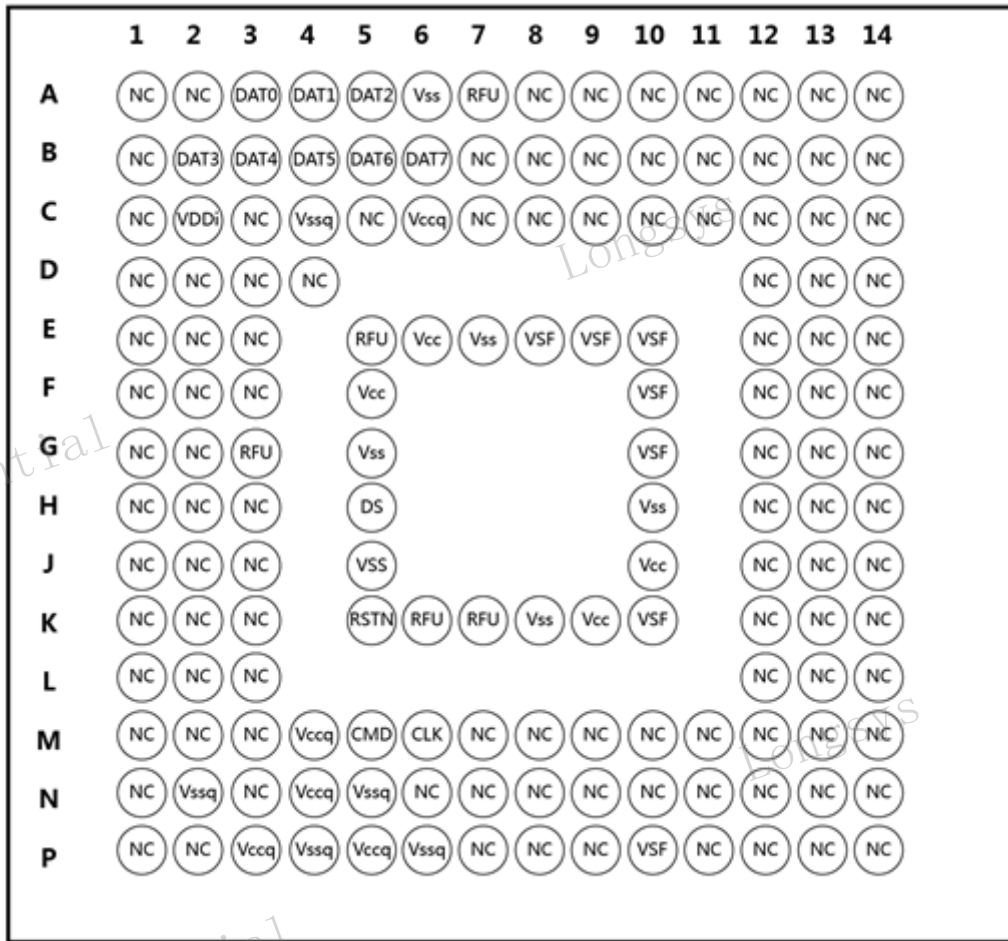

FBGA153 - Ball Array (Ball side down view)

6.2 Ball Array view

Signal	Description
CLOCK(CLK)	Each cycle of the clock directs a transfer on the command line and on the data lines.
COMMAND(CMD)	This signal is a bidirectional command channel used for device initialization and command transfer. The CMD Signal has 2 operation modes: open drain, for initialization, and push-pull, for command transfer. Commands are sent from the host to the device, and responses are sent from the device to the host.
DATA(DAT0-DAT7)	These are bidirectional data signal. The DAT signals operate in push-pull mode. By default, after power-up or RESET, only DAT0 is used for data transfer. The controller can configure a wider data bus for data transfer wither using DAT [3:0](4bit mode)or DAT[7:0](8bit mode). Includes internal pull-up resistors for data lines DAT[7:1].Immediately after entering the 4-bit mode, the device disconnects the internal pull-up resistors on the DAT1 and DAT2 lines.(The DAT3 line internal pull-up is left connected.)Upon entering the 8bit mode, the device disconnects the internal pull-up on the DAT1, DAT2, and DAT[7:4]lines.

Signal	Description
Data Strobe(DS)	Newly assigned pin for HS400 mode. Data Strobe is generated from e.MMC to host. In HS400 mode, read data and CRC response are synchronized with Data Strobe.
RESET(RSTN)	Hardware Reset Input
Vccq	Vccq is the power supply line for host interface, have two power mode: High power mode:2.7V~3.6V; Lower power mode:1.7V~1.95V
Vcc	Vcc is the power supply line for internal flash memory, its power voltage range is:2.7V~3.6V
VDDi	VDDi is internal power node, not the power supply. Connect 1uF capacitor VDDi to ground
Vss,Vssq	Ground lines.

Note:

NC: No Connect, shall be connected to ground or left floating.

RFU: Reserved for Future Use, must be left floating for future use.

VSF: Vendor Specific Function, must be left floating.

7. Usage Overview

7.1 General description

The eMMC can be operated in 1, 4, or 8-bit mode. NAND flash memory is managed by a controller inside, which manages ECC, wear leveling and bad block management. The eMMC provides easy integration with the host process that all flash management hassles are invisible to the host.

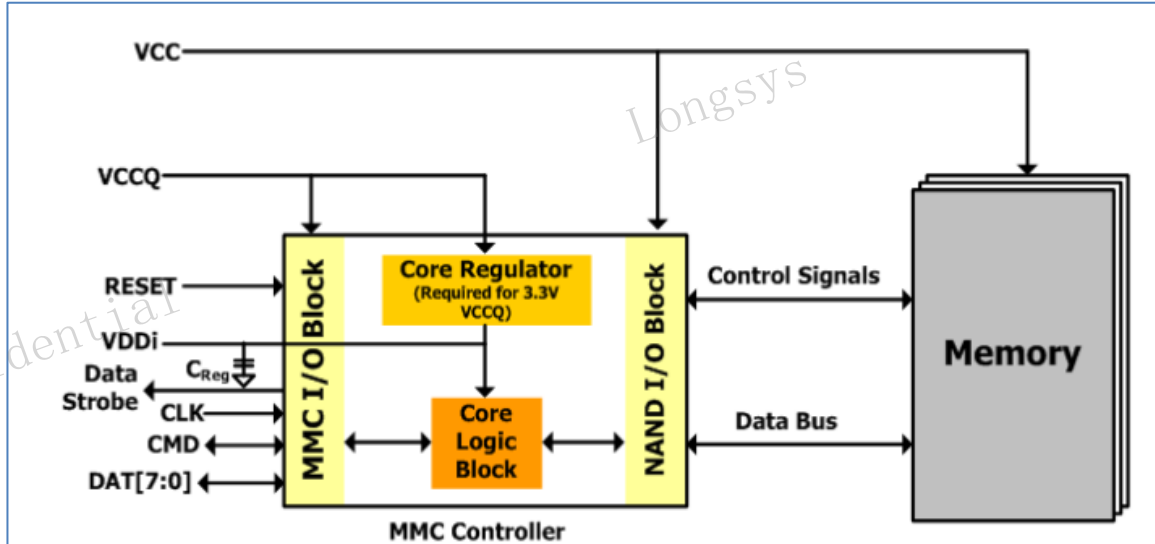

7.2 Partition Management

The embedded device offers also the possibility of configuring by the host additional split local memory partitions with independent addressable space starting from logical address 0x00000000 for different usage models. Default size of each Boot Area Partition is 4096 KB and can be changed by Vendor Command as multiple of 128KB. Boot area partition size is calculated as (128KB * BOOT_SIZE_MULTI) The size of Boot Area Partition 1 and 2 cannot be set independently and is set as same value Boot area partition which is enhanced partition. Therefore memory block area scan is classified as follows:

- Factory configuration supplies boot partitions.
- **The RPMB partition is 4MB.**
- The host is free to configure one segment in the User Data Area to be implemented as enhanced storage media, and to specify its starting location and size in terms of Write Protect Groups. The attributes of this Enhanced User Data Area can be programmed only once during the device life-cycle (one-time programmable).
- Up to four General Purpose Area Partitions can be configured to store user data or sensitive data, or for other host usage models. The size of these partitions is a multiple of the write protect group. Size and attributes can be programmed once in device life-cycle (one-time programmable). Each of the General Purpose Area Partitions can be implemented with enhanced technological features.

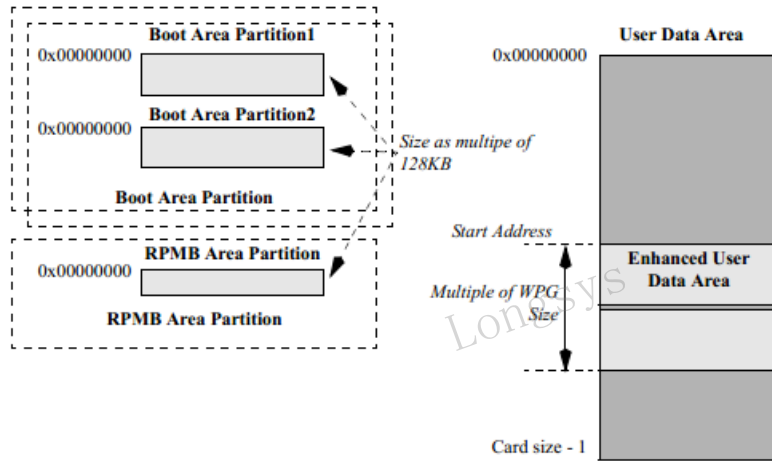

Partitions and user data area configuration

(The size of RPMB area partition is 4MB)

In boot operation mode, the master can read boot data from the slave (device) by keeping CMD line low or sending CMD0 with argument + 0xFFFFFFFF, before issuing CMD1. The data can be read from either boot area or user area depending on register setting.

Timing Factor	Value
Boot ACK Time	< 50 ms
Boot Data Time	< 1 s
Initialization Time	< 1 s

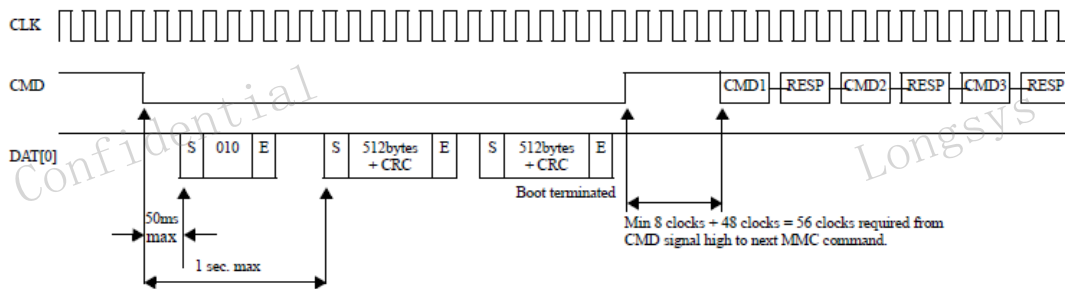

State diagram (boot mode)

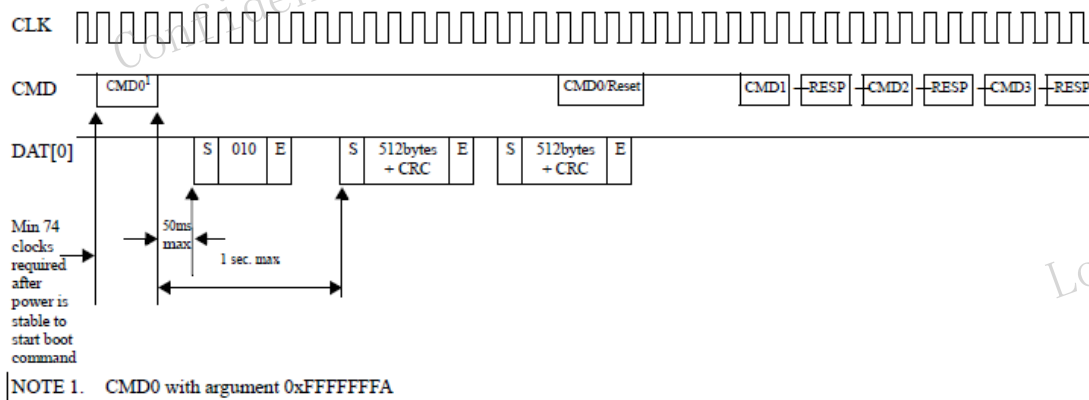

State diagram (alternative boot mode)

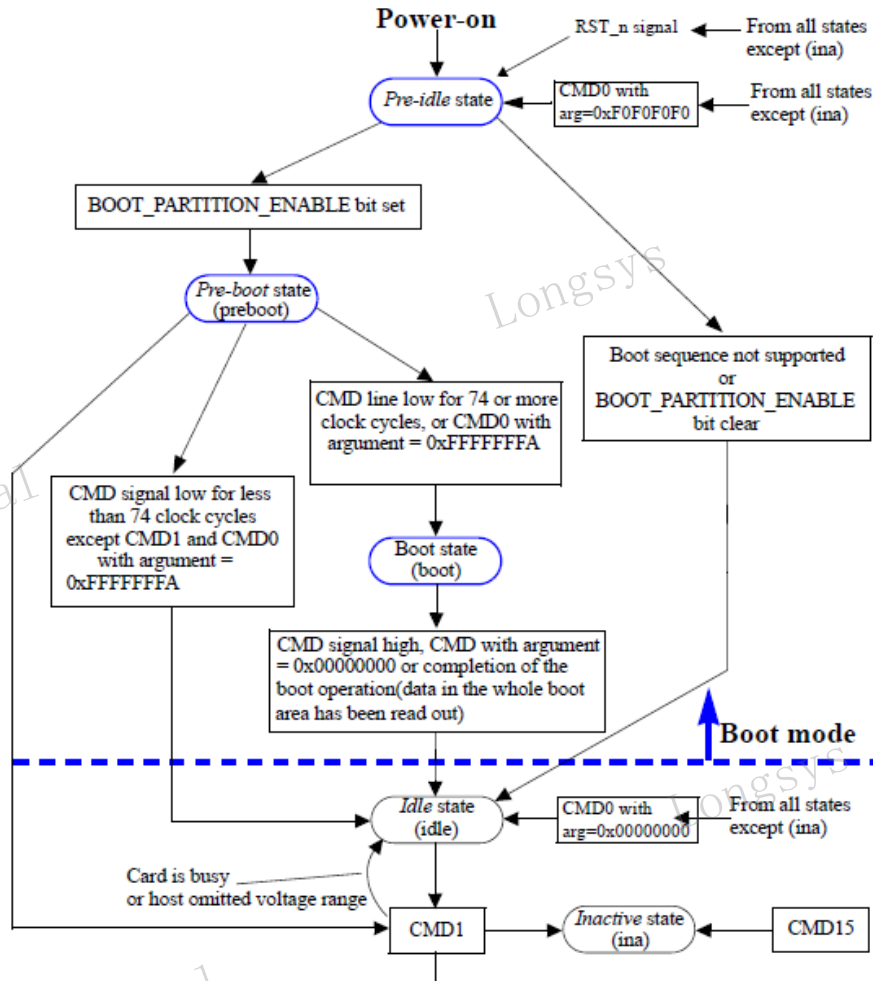

State diagram (boot mode)*

7.3 Automatic Sleep Mode

If host does not issue any command during certain duration (**1s**), after previously issued command is completed, the device enters "Power Saving mode" to reduce power consumption. At this time, commands arriving at the device while it is in power saving mode will be serviced in normal fashion. The below table explains the condition to enter and exit Auto Power Saving Mode

7.4 Sleep (CMD5)

A card may be switched between a Sleep state and a Standby state by SLEEP/AWAKE (CMD5). In the Sleep state the power consumption of the memory device is minimized. In this state the memory device reacts only to the commands RESET (CMD0 with argument of either 0x00000000 or 0xF0F0F0F0 or H/W reset) and SLEEP/AWAKE (CMD5). All the other commands are ignored by the memory device. The timeout for state transitions between Standby state and Sleep state is defined in the EXT_CSD register S_A_timeout. The maximum current consumptions during the Sleep state are defined in the EXT_CSD registers S_A_VCC and S_A_VCCQ. Sleep command: The bit 15 as set to 1 in SLEEP/ AWAKE (CMD5) argument. A wake command: The bit 15 as set to 0 in SLEEP/AWAKE (CMD5) argument.

7.5 H/W Reset operation

Device will detect the rising edge of RST_n signal to trigger internal reset sequence

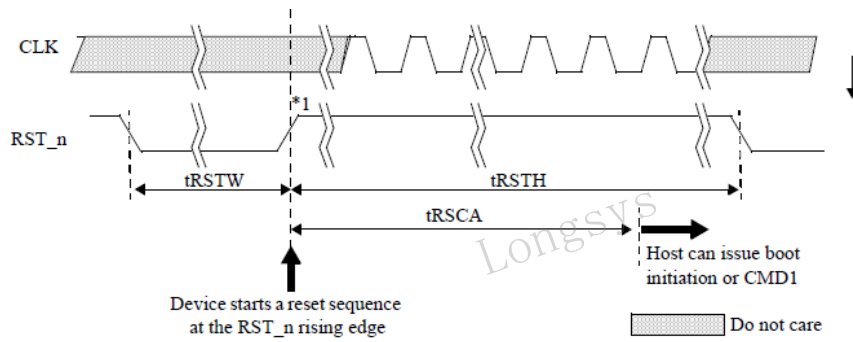

H/W reset waveform

7.6 High-speed mode selection

After the host verifies that the card complies with version 4.0, or higher, of this standard, it has to enable the high speed mode timing in the card, before changing the clock frequency to a frequency higher than 20MHz. For the host to change to a higher clock frequency, it has to enable the high speed interface timing. The host uses the SWITCH command to write 0x01 to the HS_TIMING byte, in the Modes segment of the EXT_CSD register.

7.7 Bus width selection

After the host has verified the functional pins on the bus it should change the bus width configuration accordingly, using the SWITCH command. The bus width configuration is changed by writing to the BUS_WIDTH byte in the Modes Segment of the EXT_CSD register (using the SWITCH command to do so). After power-on, or software reset, the contents of the BUS_WIDTH byte is 0x00.

7.8 Partition configuration

Model	Area/Partition	Size (GB)	Size (MB)	Size (Sector)	Size (Byte)	Size (Hex, Byte)
FEMDNN016G-58A43	User	14.58	14940	30597120	15665725440	3A5C00000
	Boot Partition 1	-	4	8192	4194304	400000
	Boot Partition 2	-	4	8192	4194304	400000
	RPMB	-	4	8192	4194304	400000

7.9 CID register

The Card Identification (CID) register is 128 bits wide. It contains the card identification information used during the card identification phase (protocol). Every individual flash or I/O card shall have a unique identification number. Every type of ROM cards (defined by content) shall have a unique identification number. The structure of the CID register is defined in the following sections.

Name	Field	Width	CID-slice	CID Value	Remark
Manufacturer ID	MID	8	[127:120]	D6h	
Reserved	-	6	[119:114]	--	
Card/BGA	CBX	2	[113:112]	01h	BGA

Name	Field	Width	CID-slice	CID Value	Remark
OEM/Application ID	OID	8	[111:104]	03h	
Product name	PNM	48	[103:56]	0x353841343331	58A431
Product revision	PRV	8	[55:48]	--	
Product serial number	PSN	32	[47:16]	--	Not Fixed
Manufacturing date	MDT	8	[15:8]	--	Not Fixed
CRC7 checksum	CRC	7	[7:1]	--	Not Fixed
Not used, always '1'	-	1	[0:0]	--	

7.10 CSD register

The Card-Specific Data (CSD) register provides information on how to access the card contents. The CSD defines the data format, error correction type, maximum data access time, data transfer speed, whether the DSR register can be used etc. The programmable part of the register (entries marked by W or E, see below) can be changed by CMD27. The type of the CSD Registry entries coded as follows:

Name	Field	Width	Cell Type	CSD-slice
CSD structure	CSD_STRUCTURE	2	R	[127:126]
System specification version	SPEC_VERS	4	R	[125:122]
Reserved	-	2	R	[121:120]
Data read access-time 1	TAAC	8	R	[119:112]
Data read access-time 2 in CLK cycles (NSAC*100)	NSAC	8	R	[111:104]
Max. bus clock frequency	TRAN_SPEED	8	R	[103:96]
Card command classes	CCC	12	R	[95:84]
Max. read data block length	READ_BL_LEN	4	R	[83:80]
Partial blocks for read allowed	READ_BL_PARTIAL	1	R	[79:79]
Write block misalignment	WRITE_BLK_MISALIGN	1	R	[78:78]
Read block misalignment	READ_BLK_MISALIGN	1	R	[77:77]
DSR implemented	DSR_IMP	1	R	[76:76]
Reserved	-	2	R	[75:74]
Device size	C_SIZE	12	R	[73:62]
Max. read current @ V_{DD} min	VDD_R_CURR_MIN	3	R	[61:59]
Max. read current @ V_{DD} max	VDD_R_CURR_MAX	3	R	[58:56]
Max. write current @ V_{DD} min	VDD_W_CURR_MIN	3	R	[55:53]
Max. write current @ V_{DD} max	VDD_W_CURR_MAX	3	R	[52:50]
Device size multiplier	C_SIZE_MULT	3	R	[49:47]
Erase group size	ERASE_GRP_SIZE	5	R	[46:42]
Erase group size multiplier	ERASE_GRP_MULT	5	R	[41:37]
Write protect group size	WP_GRP_SIZE	5	R	[36:32]
Write protect group enable	WP_GRP_MULT	1	R	[31:31]
Manufacturer default ECC	DEFAULT_ECC	2	R	[30:29]
Write speed factor	R2W_FACTOR	3	R	[28:26]
Max. write data block length	WRITE_BL_LEN	4	R	[25:22]
Partial blocks for write allowed	WRITE_BL_PARTIAL	1	R	[21:21]

Name	Field	Width	Cell Type	CSD-slice
Reserved	-	4	R	[20:17]
Content protection application	CONTENT_PROT_APP	1	R	[16:16]
File format group	FILE_FORMAT_GRP	1	R/W	[15:15]
Copy flag(OTP)	COPY	1	R/W	[14:14]
Permanent write protection	PERM_WRITE_PROTECT	1	R/W	[13:13]
Temporary write protection	TMP_WRITE_PROTECT	1	R/W/E	[12:12]
File format	FILE_FORMAT	2	R/W	[11:10]
ECC code	ECC	2	R/W/E	[9:8]
CRC	CRC	7	R/W/E	[7:1]
Not used, always '1'	-	1	-	[0:0]

7.11 Extended CSD register

The Extended CSD register defines the card properties and selected modes. It is 512 bytes long. The most significant 320 bytes are the Properties segment, which defines the card capabilities and cannot be modified by the host. The lower 192 bytes are the Modes segment, which defines the configuration the card is working in. These modes can be changed by the host by means of the SWITCH command.

Name	Field	Size	Type	Slice [bytes]	Value	Description
Reserved		6	-	[511:506]	-	
Extended security error	EXT_SECURITY_ERR	1	R	[505]	0	
Supported Command Sets	S_CMD_SET	1	R	[504]	1h	
HPI Features	HPI_FEATURES	1	R	[503]	1h	
Background operations support	BKOPS_SUPPORT	1	R	[502]	1h	BKOPS supported
Max packed read command	MAX_PACKED_READS	1	R	[501]	3Fh	
Max packed write command	MAX_PACKED_WRITES	1	R	[500]	3Fh	
Data Tag Support	DATA_TAD_SUPPORT	1	R	[499]	1h	
Tag Unit Size	TAG_UNIT_SIZE	1	R	[498]	3h	
Tag Resource Size	TAG_RES_SIZE	1	R	[497]	0h	
Context management capabilities	CONTEXT_CAPABILITIES	1	R	[496]	5h	
Large Unit size	LARGE_UNIT_SIZE_M1	1	R	[495]	7h	Large Unit size 8MB

Name	Field	Size	Type	Slice [bytes]	Value	Description
Extended partitions attribute support	EXT_SUPPORT	1	R	[494]	3h	
Supported modes	SUPPORTED_MODES	1	R	[493]	3h	
FFU features	FFU_FEATURES	1	R	[492]	0h	
Operation codes timeout	OPERATION_CODE_TIMEOUT	1	R	[491]	0h	
FFU Argument	FFU_ARG	4	R	[490:487]	0h	
Barrier support	BARRIER_SUPPORT	1	R	[486]	0h	
Reserved		177	-	[485:309]	-	
CMDQ support	CMDQ_SUPPORT	1	W/R	[308]	1h	
CMDQ depth	CMDQ_DEPTH	1	W/R	[307]	1Fh	
Reserved		1	-	[306]	-	
Number of received sectors	NUMBER_OF_RECEIVED_SECTORS	4	R	[305:302]	0h	
Vendor proprietary health report	VENDOR_PROPRIETARY_HEALTH_REPORT	1	R	[301:270]	0h	
Device life time estimation type B	DEVICE_LIFE_TIME_EST_TYP_B	1	R	[269]	1h	
Device life time estimation type A	DEVICE_LIFE_TIME_EST_TYP_A	1	R	[268]	1h	
Pre EOL information	PRE_EOL_INFO	1	R	[267]	1h	
Optimal read size	OPTIMAL_READ_SIZE	1	R	[266]	0h	
Optimal write size	OPTIMAL_WRITE_SIZE	1	R	[265]	20h	
Optimal trim unit size	OPTIMAL_TRIM_UNIT_SIZE	1	R	[264]	1h	
Device version	DEVICE_VERSION	2	R	[263:262]	0h	
Firmware version	FIRMWARE_VERSION	8	R	[261:254]	-	FWPatchVer
Power class for 200MHz, DDR at VCC=3.6V	PWR_CL_DDR_200_360	1	R	[253]	0h	
Cache size	CACHE_SIZE	4	R	[252:249]	10000h	
Generic CMD6 timeout	GENERIC_CMD6_TIME	1	R	[248]	Ah	Generic CMD6 timeout 100ms

Name	Field	Size	Type	Slice [bytes]	Value	Description
Power-off notification(long) timeout	POWER_OFF_LONG_TIME	1	R	[247]	3Ch	Power off notification(long) timeout 600ms
Background operations status	BKOPS_STATUS	1	R	[246]	0h	No operations required
Number of correctly programmed sectors	CORRECTLY_PRG_SECTOR_S_NUM	4	R	[245:242]	0h	
First Initialization time after partitioning	INI_TIMEOUT_AP	1	R	[241]	1Eh	initial timeout 3s
Cache Flushing Policy	CACHE_FLUSH_POLICY	1	R	[240]	0h	
Power class for 52Mhz,DDR at 3.6V	PWR_CL_DDR_52_360	1	R	[239]	0h	rms 100 mA, peak 200 mA
Power class for 52Mhz,DDR at 1.95V	PWR_CL_DDR_52_195	1	R	[238]	0h	rms 65 mA, peak 130 mA
Power class for 200Mhz at VCCQ=1.95V, VCC=3.6V	PWR_CL_200_195	1	R	[237]	0h	
Power class for 200Mhz at VCCQ=1.3V, VCC=3.6V	PWR_CL_200_360	1	R	[236]	0h	
Minimum write performance for 8bit at 52MHz in DDR mode	MIN_PERF_DDR_W_8_52	1	R	[235]	0h	For cards not reaching the 4.8 MB/s value Only support SDR
Minimum read performance for 8bit at 52MHz in DDR mode	MIN_PERF_DDR_R_8_52	1	R	[234]	0h	For cards not reaching the 4.8MB/s value

Name	Field	Size	Type	Slice [bytes]	Value	Description
	Reserved	1	-	[233]	-	
TRIM Multiplier	TRIM_MULT	1	R	[232]	5h	trim time out 1.5s
Secure feature support	SEC_FEATURE_SUPPORT	1	R	[231]	55h	<ol style="list-style-type: none"> 1. Support the secure and insecure trim operations. 2. Support the automatic secure purge operation on retired defective portions of the array. 3. Secure purge operations are supported. 4. Support the sanitize operation
Secure Erase Multiplier	SEC_ERASE_MULT	1	R	[230]	1Bh	secure erase time out 40.5s
Secure TRIM Multiplier	SEC_TRIM_MULT	1	R	[229]	11h	secure trim time out 25.5s

Name	Field	Size	Type	Slice [bytes]	Value	Description
Boot Information	BOOT_INFO	1	R	[228]	7h	<ol style="list-style-type: none"> Support high speed timing boot. Support dual data rate during boot Support alternative boot method
Reserved		1	-	[227]	-	
Boot partition size	BOOT_SIZE_MULTI	1	R	[226]	20h	boot partition 4096KB
Access size	ACC_SIZE	1	R	[225]	6h	super page 16KB
High-capacity Erase unit size	HC_ERASE_GROUP_SIZE	1	R	[224]	1h	hc erase group size 512KB
High-capacity Erase time out	ERASE_TIMEOU_MULT	1	R	[223]	5h	hc erase time out 1.5s
Reliable write sector count	REL_WR_SEC_C	1	R	[222]	1h	1 sector
High-capacity write protect group size	HC_WP_GRP_SIZE	1	R	[221]	8h	hc wp group size 4096KB
Sleep current(VCC)	S_C_VCC	1	R	[220]	7h	128μA
Sleep current[VCCQ]	S_C_VCCQ	1	R	[219]	7h	128μA
Production state awareness timeout	PRODUCTION_STATE_AWARENESS_TIMEOUT	1	R	[218]	0h	Not defined
Sleep/Awake time out	S_A_TIMEOUT	1	R	[217]	16h	Sleep/Awake timeout 419.43ms

Name	Field	Size	Type	Slice [bytes]	Value	Description
Sleep Notification Time out	SLEEP_NOTIFICATION_TIME	1	R	[216]	10h	Sleep Notification Time out 655.36ms
Sector count	SEC_COUNT	4	R	[215:212]	1D2E000h	
Secure Write Protection Mode	SECURE_WP_INFO	1		[211]	1h	
Minimum Write Performance for 8bit @52MHz	MIN_PERF_W_8_52	1	R	[210]	0h	
Minimum Read Performance for 8bit @52MHz	MIN_PERF_R_8_52	1	R	[209]	0h	
Minimum Write Performance for 4bit @52MHz or 8bit @26MHz	MIN_PERF_W_8_26_4_52	1	R	[208]	0h	
Minimum Read Performance for 4bit @52MHz or 8bit @26MHz	MIN_PERF_R_8_26_4_52	1	R	[207]	0h	
Minimum Write Performance for 4bit @26MHz	MIN_PERF_W_4_26	1	R	[206]	0h	
Minimum Read Performance for 4bit @26MHz	MIN_PERF_R_4_26	1	R	[205]	0h	
Reserved		1	-	[204]	-	
Power Class for 26MHz @3.6V	PWR_CL_26_360	1	R	[203]	0h	rms 100 mA, peak 200 mA
Power Class for 52MHz @3.6V	PWR_CL_52_360	1	R	[202]	0h	rms 100 mA, peak 200 mA
Power Class for 26MHz @1.95V	PWR_CL_26_195	1	R	[201]	0h	rms 65 mA, peak 130 mA
Power Class for 52MHz @1.95V	PWR_CL_52_195	1	R	[200]	0h	rms 65 mA, peak 130 mA

Name	Field	Size	Type	Slice [bytes]	Value	Description
Partition switching timing	PARTITION_SWITCH_TIME	1	R	[199]	Ah	Partition switch time out 100ms
Out-of-interrupt busy timing	OUT_OF_INTERRUPT_TIME	1	R	[198]	5h	HPI time out 50ms
I/O Driver Strength	DRIVER_STRENGTH	1	R	[197]	1Fh	
Card Type	CARD_TYPE	1	R	[196]	57h	HS400 DDR eMMC@200 Mhz-1.8V I/O
	Reserved	1	-	[195]	-	
CSD Structure Version	CSD_STRUCTURE	1	R	[194]	2h	CSD version No. 1.2
	Reserved	1	-	[193]	-	
Extended CSD Revision	EXT_CSD_REV	1	R	[192]	8h	Revision 1.8 (for MMC v5.1)
Command Set	CMD_SET	1	R/W/E_P	[191]	0h	
	Reserved	1	-	[190]	-	
Command set revision	CMD_SET_REV	1	R	[189]	0h	
	Reserved	1	-	[188]	-	
Power class	POWER_CLASS	1	R/W/E_P	[187]	0h	
	Reserved	1	-	[186]	-	
High Speed Interface Timing	HS_TIMING	1	R/W/E_P	[185]	0h	
Strobe Support	STROBE_SUPPORT	1	R	[184]	1h	
Bus Width Mode	BUS_WIDTH	1	W/E_P	[183]	0h	
	Reserved	1	-	[182]	-	
Erased memory range	ERASE_MEM_CONT	1	R	[181]	0h	
	Reserved	1	-	[180]	-	
Partition Configuration	PARTITION_CONFIG	1	R/W/E R/W/E_P	[179]	0h	
Boot config protection	BOOT_CONFIG_PROT	1	R/W R/W/C_P	[178]	0h	
Boot bus width1	BOOT_BUS_WIDTH	1	R/W/E	[177]	0h	
	Reserved	1	-	[176]	-	

Name	Field	Size	Type	Slice [bytes]	Value	Description
High-density erase group definition	ERASE_GROUP_DEF	1	R/W/E_P	[175]	0h	
Boot write protection status registers	BOOT_WP_STATUS	1	R	[174]	0h	
Boot area write protect register	BOOT_WP	1	R/W R/W/C_P	[173]	0h	
Reserved		1	-	[172]	-	
User area write protect register	USER_WP	1	R/W R/W/C_P R/W/E_P	[171]	0h	
Reserved		1	-	[170]	-	
FW Configuration	FW_CONFIG	1	R/W	[169]	0h	
RPMB Size	RPMB_SIZE_MULT	1	R	[168]	20h	RPMB size is 4MB
Write reliability setting register	WR_REL_SET	1	R/W	[167]	1Fh	
Write reliability parameter register	WR_REL_PARAM	1	R	[166]	15h	Support the enhanced definition of reliable write
Start Sanitize operation	SANITIZE_START	1	W/E_P	[165]	0h	
Manually start background operations	BKOPS_START	1	W/E_P	[164]	0h	
Enable background operations handshake	BKOPS_EN	1	R/W	[163]	0h	
H/W reset function	RST_n_FUNCTION	1	R/W	[162]	0h	
HPI management	HPI_MGMT	1	R/W/E_P	[161]	0h	

Name	Field	Size	Type	Slice [bytes]	Value	Description
Partitioning support	PARTITIONING_SUPPORT	1	R	[160]	7h	1. Enhanced technological features in partitions and user data area. 2. Device supports partitioning features 3. Device can have extended partition attribute
Max Enhanced Area Size	MAX_ENH_SIZE_MULT	3	R	[159:157]	NA	
Partitions attribute	PARTITIONS_ATTRIBUTE	1	R/W	[156]	0h	
Partitions setting	PARTITIONS_SETTING_COMPLETED	1	R/W	[155]	0h	
General Purpose Partition Size	GP_SIZE_MULT	12	R/W	[154:143]	0h	
Enhanced User Data Area Size	ENH_SIZE_MULT	3	R/W	[142:140]	0h	
Enhanced User Data Start Address	ENH_START_ADDR	4	R/W	[139:136]	0h	
Reserved		1	-	[135]	-	
Secure Bad Block Management Mode	SEC_BAD_BLK_MGMNT	1	R/W	[134]	0h	
Production state awareness	PRODUCTION_STATE_AWARENESS	1	R/W/E	[133]	0h	
Package Case Temperature is controlled	TCASE_SUPPORT	1	W/E_P	[132]	0h	
Periodic Wake-up	PERIODIC_WAKEUP	1	R/W/E	[131]	0h	
Program CID/CSD in DDR mode support	PROGRAM_CID_CSD_DDR_SUPPORT	1	R	[130]	1h	
Reserved		2	-	[129:128]	-	

Name	Field	Size	Type	Slice [bytes]	Value	Description
Vendor specific field	VENDOR_SPECIFIC_FIELD	64	<vendor specific>	[127:64]	0h	
Native sector size	NATIVE_SECTOR_SIZE	1	R	[63]	0h	
Sector size emulation	USE_NATIVE_SECTOR	1	R/W	[62]	0h	
Sector size	DATA_SECTOR_SIZE	1	R	[61]	0h	
1st initialization after disabling sector size emulation	INI_TIMEOUT_EMU	1	R	[60]	0h	
Class 6 commands control	CLASS_6_CTRL	1	R/W/E_P	[59]	0h	
Number of addressed group to be Released	DYNCAP_NEEDED	1	R	[58]	0h	
Exception events control	EXCEPTION_EVENTS_CTRL	2	R/W/E_P	[57:56]	0h	
Exception events status	EXCEPTION_EVENTS_STATUS	2	R	[55:54]	0h	
Extended Partitions Attribute	EXT_PARTITIONS_ATTRIBUTE	2	R/W	[53:52]	0h	
Context configuration	CONTEXT_CONF	15	R/W/E_P	[51:37]	0h	
Packed command status	PACKED_COMMAND_STATUS	1	R	[36]	0h	
Packed command failure index	PACKED_FAILURE_INDEX	1	R	[35]	0h	
Power Off Notification	POWER_OFF_NOTIFICATION	1	R/W/E_P	[34]	0h	
Control to turn the Cache ON/OFF	ON/OFF_CACHE_CTRL	1	R/W/E_P	[33]	0h	
Flushing of the cache	FLUSH_CACHE	1	W/E_P	[32]	0h	
Control to turn the Barrier ON/OFF	ON/OFF_BARRIER_CTRL	1	R/W	[31]	0h	
Mode config	MODE_CONFIG	1	R/W/E_P	[30]	0h	
Mode operation codes	MODE_OPERATION_CODES	1	W/E_P	[29]	0h	

Name	Field	Size	Type	Slice [bytes]	Value	Description
Reserved		2	-	[28:27]	-	
FFU status	FFU_STATUS	1	R	[26]	0h	
Pre loading data size	PRE_LOADING_DATA_SIZE	4	R/W/E_P	[25:22]	0h	
Max pre loading data size	MAX_PRE_LOADING_DATA_SIZE	4	R	[21:18]	-	
Product state awareness enablement	PRODUCT_STATE_AWARENESS_ENABLEMENT	1	R/W/E&R	[17]	0h	
Secure Removal Type	SECURE_REMOVAL_TYPE	1	R/W&R	[16]	9h	
Command Queue Mode Enable	CMDQ_MODE_EN	1	R/W/E_P	[15]	0h	
Reserved		15	-	[14:0]	-	

- Notes:**
1. R= Read-only
 R/W=One-Time Programmable and readable
 R/W/E=Multiple writable with value kept after a power cycle, assertion of the RST_n signal, and any CMD0 reset, and readable
 TBD=To Be Defined.
 2. Reserved bits should be read as 0.

7.12 OCR Register

The 32-bit operation conditions register stores the VCCQ voltage profile of the eMMC. In addition, this register includes a status information bit. This status bit is set if the eMMC power up procedure has been finished. The OCR register shall be implemented by eMMC.

OCR bit	VCCQ voltage window	eMMC
[6:0]	Reserved	000 0000b
[7]	1.7–1.95	1b
[14:8]	2.0–2.6	000 0000b
[23:15]	2.7–3.6	1 1111 1111b
[28:24]	Reserved	000 0000b
[30:29]	Access Mode	00b (byte mode)/10b (sector mode)
[31]	power up status bit (busy)*	

Note*: This bit is set to LOW if the eMMC has not finished the power up routine. The supported voltage range is coded as shown in table.

7.13 Field firmware update(FFU)

To download a new firmware, the controller requires instruction sequence following JEDEC standard. Longsys eMMC only supports Manual mode (MODE_OPERATION_CODES is not supported). For more details, refer to the App note.

Longsys eMMC Field F/W update flow - CMD sequence

Operation	CMD	Remark
Set block length 512B	CMD16, arg : 0x00000200	
Enter FFU mode	CMD6, arg : 0x031E0100	
Send FW to device(Download)	CMD25, arg : 0x00000000	Sending CMD25 is followed by sending FW data ,The whole data should be sent by one CMD25
CMD12 : Stop	CMD12, arg : 0x00000000	
CMD6 : Exit FFU mode	CMD6, arg : 0x031E0000	
HW Reset/Power cycle		CMD0 Reset is not support
Re-Init to trans state	CMD0, CMD1 ...	
Check if FFU is succeeded	CMD8, arg : 0x00000000	Check EXT_CSD[26] : FFU_SUCCESS If FFU_SUCCESS is 0, FFU is succeeded, otherwise FFU is failed.Do not verify data with CMD17/CMD18 while FFU mode.

SUPPORTED_MODE[493] (Read Only)

BIT[0] : '0' FFU is not supported by the device.

'1' FFU is supported by the device.

BIT[1] : '0' Vendor specific mode (VSM) is not supported by the device.

'1' Vendor specific mode is supported by the device.

Bit	Field	Supportability
Bit[7:2]	Reserved	-
Bit[1]	VSM	Not support
Bit[0]	FFU	Support

FFU_FEATURE[492] (Read Only)

BIT[0] : '0' Device does not support MODE_OPERATION_CODES field (Manual mode)

'1' Device supports MODE_OPERATION_CODES field (Auto mode)

Bit	Field	Supportability
Bit[7:1]	Reserved	-
Bit[0]	SUPPORTED_MODE_OPERATION_CODES	Not support

FFU_ARG[490-487] (Read Only)

Using this field the device reports to the host which value the host should set as an argument for read and write commands in FFU mode.

FW_CONFIG[169] (R/W)

BIT[0] : Update disable

0x0 : FW updates enabled.

0x1 : FW update disabled permanently

Bit	Field	Supportability
Bit[7:1]	Reserved	-
Bit[0]	Update disable	FW updates enabled (0x0)

FFU_STATUS[26] (R/W/E_P)

Using this field the device reports to the host the state of FFU process

Value	Description
0x13 ~ 0xFF	Reserved
0x12	Error in downloading Firmware
0x11	Firmware install error
0x10	General error
0x01 ~ 0x0F	Reserved
0x00	Success

OPERATION_CODES_TIMEOUT[491](Read Only)

Maximum timeout for the SWITCH command when setting a value to the MODE_OPERATION_CODES field. The register is set to '0', because the controller doesn't support MODE_OPERATION_CODES.

Value	Description	Timeout value
0x01 ~ 0x17	MODE_OPERATION_CODES_TIMEOUT = 100us x 2OPERATION_CODES_TIMEOUT	(Not defined)
0x18 ~ 0xFF	Reserved	-

MODE_OPERATION_CODES[29] (W/E_P)

The host sets the operation to be performed at the selected mode, in case MODE_CONFIGS is set to FFU_MODE, MODE_OPERATION_CODES could have the following values :

Value	Description
0x01	FFU_INSTALL
0x02	FFU_ABORT
0x00, others	Reserved

7.14 S.M.A.R.T. Health Report

S.M.A.R.T. is a monitoring system that detects and reports on various indicators of eMMC reliability (Including original bad blocks, increased bad blocks, power-up number, power-loss counts and etc), with the intent of enabling the anticipation of hardware failures. We may be able to use recorded S.M.A.R.T. data to discover where the faults lie, ensure how to solve the problems and prevent them from recurring in future eMMC designs (For details, please refer to app note).

8. Package Dimension

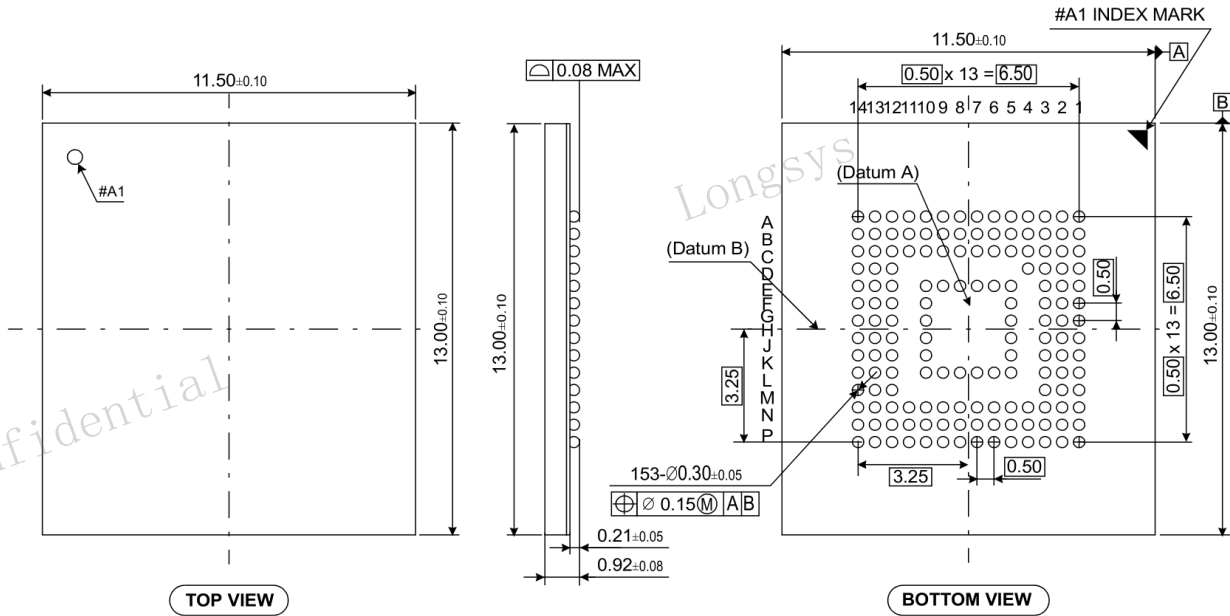

11.5mm x 13.0mm x 1.0mm Package Dimension

9 Connection Guide

9.1 Schematic Diagram

- Coupling capacitor should be connected with VCC/VCCQ and VSS as closely as possible.
- The resistance on the CLK line is highly recommended (0Ω by default). 0Ω~100Ω is also available.
- LONGSYS recommends to separate VCC and VCCQ power.
- VDDi Capacitor is min 0.1uF.
- LONGSYS recommends lay the VSS between the CLK and the Data lines.

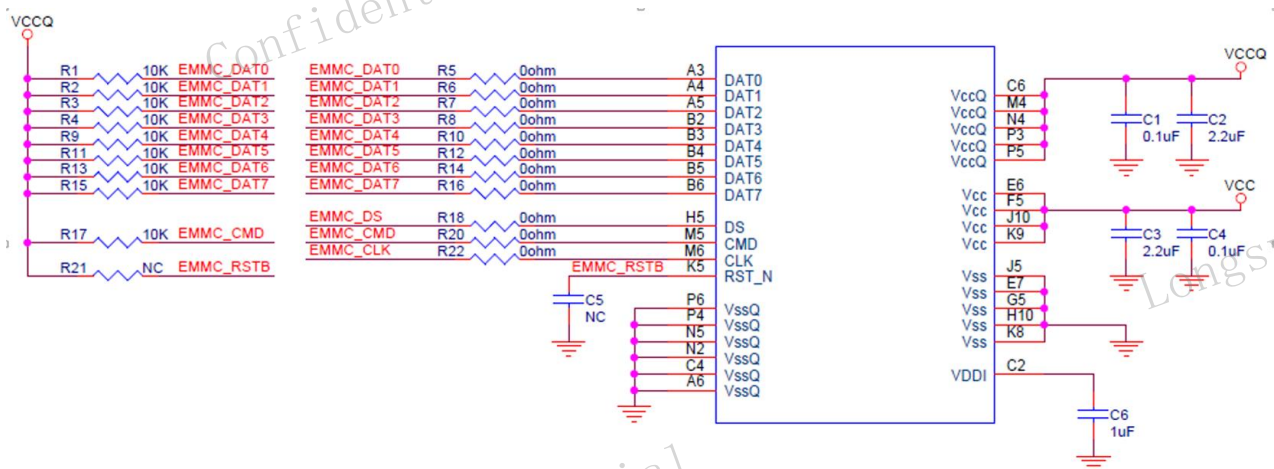

The resistance on the CLK line is highly recommended (0Ω by default)

10. Processing Guide

It is recommended to follow the instructions of Moisture Sensitivity Level 3.

In the case of Pre-program before SMT, It is highly recommended to limit the size of data pre-programmed to the eMMC, please contact your agency for more information.

- The amount of data pre-programmed (data written before SMT) is limited, it should be managed properly.
- Maximum size for the data-written to IDA.

Part Number	Size limited for Pre-programmed Data
FEMDNN016G-58A43	7.2GB