

## 5V/1A Synchronous Boost with 1A Linear Charger for Power Bank

### DESCRIPTION

The ETA9638 is a fully integrated power management unit specifically designed for Power Bank, Mobile Charger, Backup Battery Charger applications. It consists of a high efficiency synchronous step-up boost converter and a linear battery charger. The boost can provide up to 1A output current at 5V of from a Li-Ion battery input voltage, while the charger can charge up to 1A of current from an AC adapter input. The boost incorporates circuits that disconnect the input from output, during shutdown, short-circuit, output current overloading, or other events when output is higher than the input. This not only eliminates the need for an external MOSFET and its control circuitry to disconnect the input from output, also provides robust output overload protection. Using a patent pending technique to drive the charger LED indicator, it eliminates the need for a micro-controller normally needed in mobile chargers. While saving the cost of a micro-controller, since the whole units only consumes less than 100uA of quiescent current during no load, when considering standby time for one charge, it is a much superior solution comparing to the traditional solution that needs a micro-controller which normally consumes up to 1mA current.

ETA9638 is available in ESDP8 package.

### FEATURES

- ◆ 2in 1: A Synchronous boost plus A Charger
- ◆ Short-circuit Protection
- ◆ 5W Output Power for the Boost
- ◆ Boost Output to Input Reversed Current Protection
- ◆ Up to 1A Charging
- ◆ Up to 96% Efficiency during Boosting
- ◆ 100uA No load I<sub>q</sub>
- ◆ Programmable Charging Current

### APPLICATIONS

- ◆ Portable Power Bank
- ◆ Portable 3G/4G WiFi Hotspot
- ◆ Tablet PC
- ◆ Portable Device power with Li-ion battery and USB output

### ORDERING INFORMATION

PART	PACKAGE PIN	TOP MARK
ETA9638E8A	ESDP-8	ETA9638 YWWL ( Date Code)

### TYPICAL APPLICATION

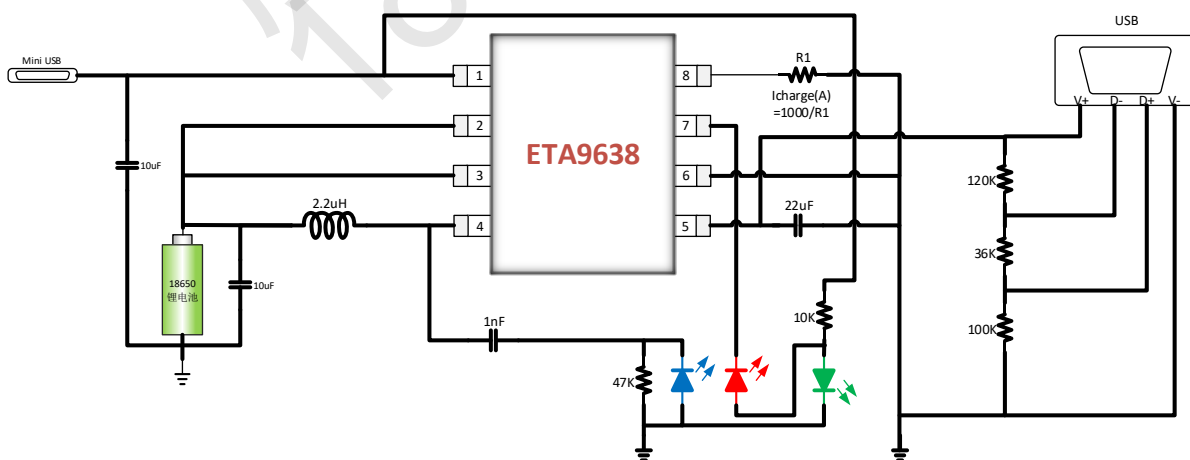

Typical Application Circuit

## ABSOLUTE MAXIMUM RATINGS

(Note: Exceeding these limits may damage the device. Exposure to absolute maximum rating conditions for long periods may affect device reliability.)

Pin1 Voltage .....	-0.3V to 6.0V
Pin5 Voltage .....	-0.3V to 5.0V
All Other Pin Except Pin5 Voltage .....	V <sub>IN</sub> -0.3V to V <sub>IN</sub> +0.3
Pin4 to ground current.....	Internally limited
Operating Temperature Range .....	-40°C to 85°C
Storage Temperature Range .....	-55°C to 150°C
Thermal Resistance	$\theta_{JA}$ $\theta_{JC}$
ESOP-8.....	50 ..... 10..... °C/W

## ELECTRICAL CHARACTERISTICS

(V<sub>IN</sub> = 3.6V, V<sub>OUT</sub> = 5V, unless otherwise specified. Typical values are at TA = 25°C.)

PARAMETER	CONDITIONS	MIN	TYP	MAX	UNITS
Output USB Voltage Range		4.8	5.0	5.2	V
Quiescent Current from battery	V <sub>battery</sub> =3.6V, No load		100		μA
Shutdown Supply Current from battery	V <sub>pin3</sub> =GND		0.5	5	μA
Switching Frequency		1.2	1.8	2.4	MHz
Maximum Duty Cycle		90			%
Switch Current Limit		1.8	2.1		A
Input miniUSB Voltage		4.5		6.0	V
Charge Termination Voltage		4.15	4.2	4.24	V
Recharge Threshold			4.05		V
Trickle Charge Voltage threshold			2.9		V
Charging Current	=1000/R <sub>I</sub> , when R <sub>I</sub> =1K,	0.85	1	1.15	A
Trickle Charge Current			45		mA
Termination Charge Current Threshold	=I <sub>term</sub> /I <sub>charge_set</sub>		0.1		
LED Sink Current			5		mA
Thermal Regulation Temperature	Charge mode		120		°C
	Boost mode		75		°C
Thermal Shutdown Temperature	HYS=15°C		150		°C

## TYPICAL CHARACTERISTICS

(Typical values are at  $T_A = 25^\circ\text{C}$  unless otherwise specified.)

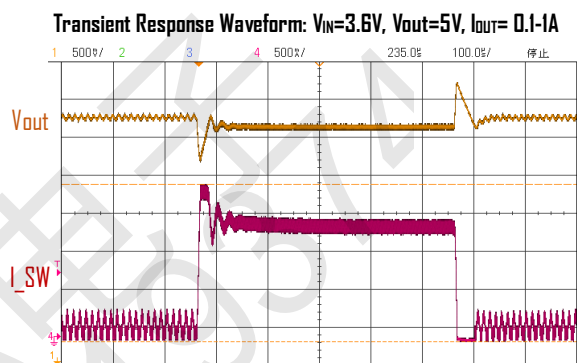
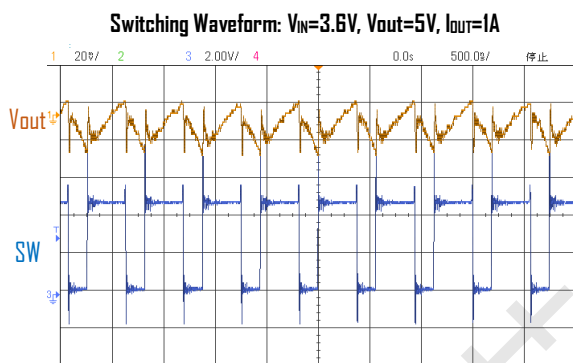
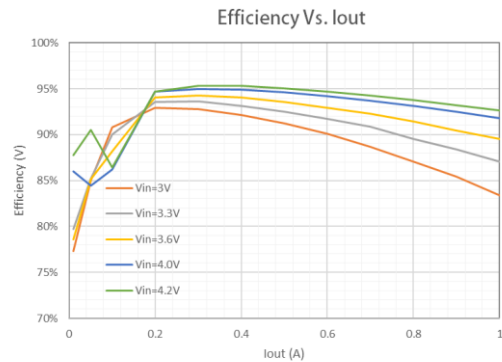
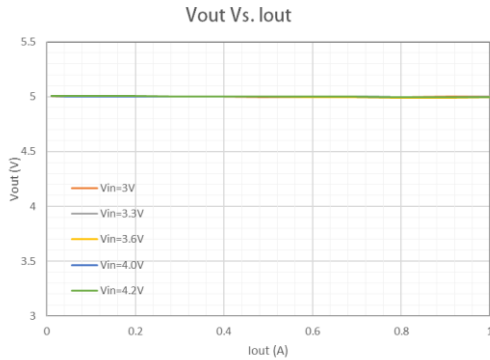

## APPLICATION NOTES

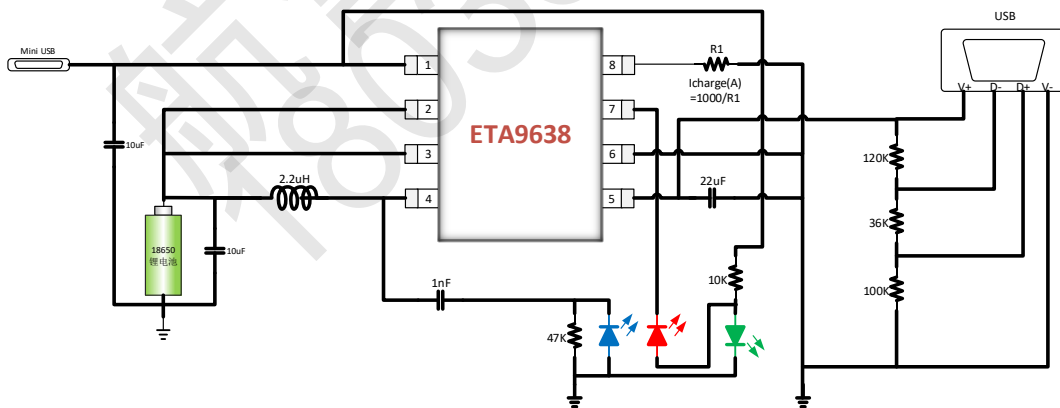

The ETA9638 is designed dedicated for a Li-ion powered system with 1A USB output port, such as portable power bank. A complete application circuit is shown above, where one can find very few peripheral devices needed. The 120K/36K/120K serial resistor is just for the iPhone charging port setup, which is not necessary for all systems. One can also simply short the D+ and D- pin of the USB output port to achieve the same function.

The blue LED with 1nF capacitor and 47K resistor filter is for an output indicator, which can also be removed if one don't need this indicator. The red LED is to indicate a charging state, and the green LED only turns on when red LED is off. Please make sure the forward voltage (Vf) of red LED is smaller than that of green LED, though it is normally true for most cases.

### *Customer service*

Please contact your dealer or directly e-mail customer service of ETA Solutions for detail information of ETA9638.

8033419374  
航嘉芯电子

### PCB LAYOUT GUIDELINE

A recommended PCB layout is shown below. The capacitors, Cbat and Cout must be placed as close to the ETA9638 as possible.

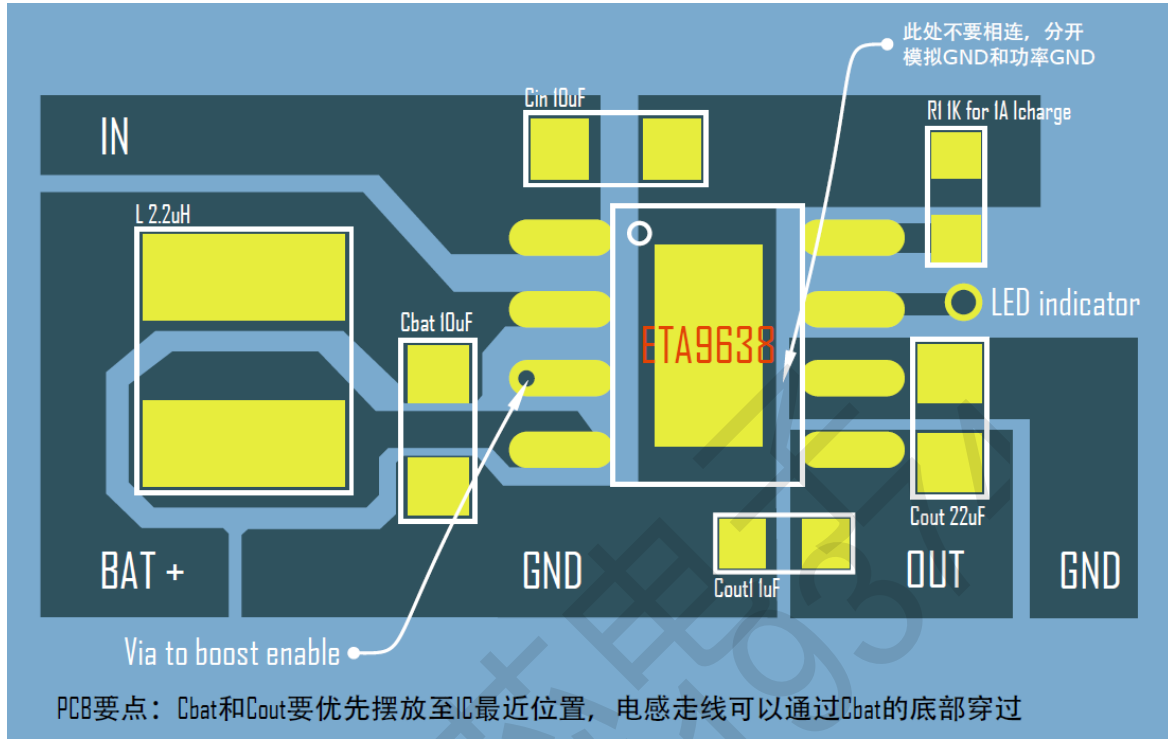

### PACKAGE OUTLINE

Package: ESOP-8

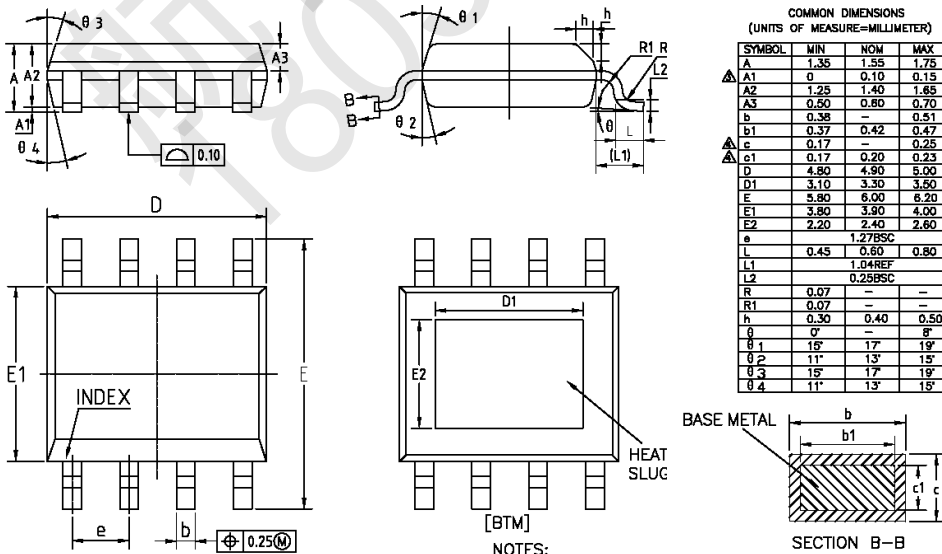

NOTES:  
ALL DIMENSIONS REFER TO JEDEC STANDARD MS-012 AA  
DO NOT INCLUDE MOLD FLASH OR PROTRUSIONS.