



CT303X, CT304X, CT306X, CT308X 6Pin Zero Cross TRIAC Driver Coupler

CT Micro

Features

- High isolation 5000 VRMS
- Peak Breakdown Voltage
 - 250V – CT303X
 - 400V – CT304X
 - 600V – CT306X
 - 800V – CT308X
- Temperature range - 55 °C to 100 °C

Applications

- Motor Controls
- Lamp ballasts
- Static AC Power Switch
- Solenoid/ Valve Control

Description

The CT303X, CT304X, CT306X and CT308X series consists of a Zero Cross Photo Triac optically coupled to a gallium arsenide Infrared-emitting diode in a 6-lead DIP package with bending options.

Package Outline

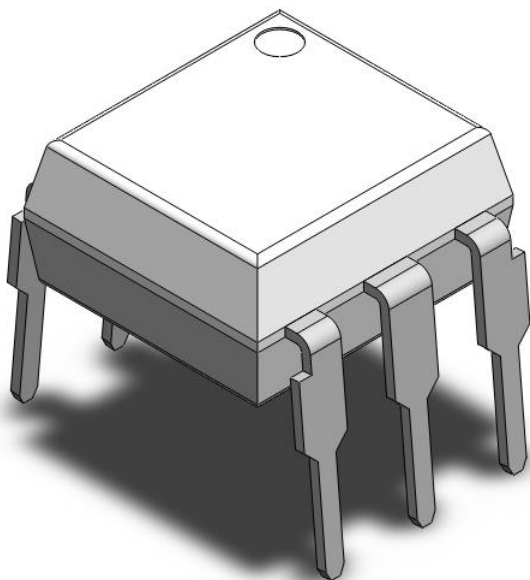

Schematic

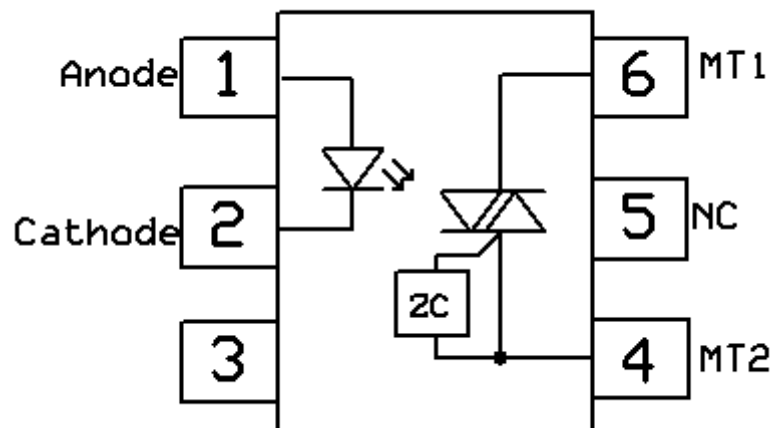

Note: Different bending options available. See package dimension.



CT303X, CT304X, CT306X, CT308X

6Pin Zero Cross TRIAC Driver Coupler

CT Micro

Absolute Maximum Rating at 25°C

Symbol	Parameters	Ratings	Units	Notes
V _{ISO}	Isolation voltage	5000	V _{RMS}	
T _{OPR}	Operating temperature	-55 ~ +100	°C	
T _{STG}	Storage temperature	-55 ~ +125	°C	
T _{SOL}	Soldering temperature	260	°C	
Emitter				
I _F	Forward current	60	mA	
I _{F(TRANS)}	Peak transient current (≤1μs P.W,300pps)	1	A	
V _R	Reverse voltage	6	V	
P _D	Power dissipation	100	mW	
Detector				
P _D	Power dissipation	300	mW	
V _{DRM}	Off-State Output Terminal Voltage	CT303X	250	V
		CT304X	400	V
		CT306X	600	V
		CT308X	800	V
I _{TSM}	Peak Repetitive Surge Current	1	A	



CT303X, CT304X, CT306X, CT308X

6Pin Zero Cross TRIAC Driver Coupler

CT Micro

Electrical Characteristics $T_A = 25^\circ\text{C}$ (unless otherwise specified)

Emitter Characteristics

Symbol	Parameters	Test Conditions	Min	Typ	Max	Units	Notes
V_F	Forward voltage	$I_F=10\text{mA}$		1.2	1.4	V	
I_R	Reverse Current	$V_R = 6\text{V}$	-	-	5	μA	
C_{IN}	Input Capacitance	$f= 1\text{MHz}$	-	45	-	pF	

Detector Characteristics

Symbol	Parameters	Test Conditions	Min	Typ	Max	Units	Notes
I_{DRM1}	Peak Blocking Current	CT303X, CT304X	$I_F= 0\text{mA}, V_{DRM}= \text{Rated } V_{DRM}$	-	-	100	nA
		CT306X, CT308X		-	-	500	
I_{DRM2}	Inhibit Leakage Current	$I_F= \text{Rated } I_{FT}, V_{DRM}= \text{Rated } V_{DRM}$			500	μA	
V_{TM}	Peak On-State Voltage	$I_F= \text{Rated } I_{FT}, I_{TM}= 100\text{mA}$	-	-	3	V	
dv/dt	Critical Rate of Rise off-State Voltage	CT303X, CT304X, CT306X	$V_{PEAK}= \text{Rated } V_{DRM}$	1000	-	-	$\text{V}/\mu\text{s}$
		CT308X		$V_{PEAK} = 400\text{V}$	600	-	

Transfer Characteristics

Symbol	Parameters	Test Conditions	Min	Typ	Max	Units	Notes
I_{FT}	Input Trigger Current	CT3031, CT3041, CT3061, CT3081	Terminal Voltage = 3V	-	-	15	V
		CT3032, CT3042, CT3062, CT3082		-	-	10	
		CT3033, CT3043, CT3063, CT3083		-	-	5	
I_H	Holding Current		-	270	-	μA	
R_{IO}	Isolation Resistance	$V_{IO}= 500\text{V}_{DC}$	1×10^{11}			Ω	
C_{IO}	Isolation Capacitance	$f= 1\text{Mhz}$		0.25		pF	



CT303X, CT304X, CT306X, CT308X 6Pin Zero Cross TRIAC Driver Coupler

CT Micro

Typical Characteristic Curves

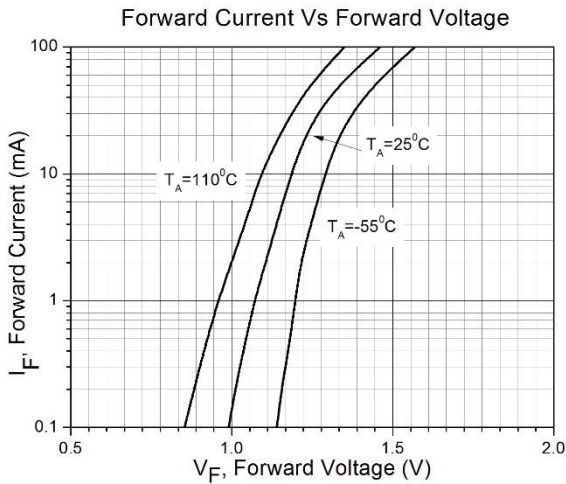

Figure 1

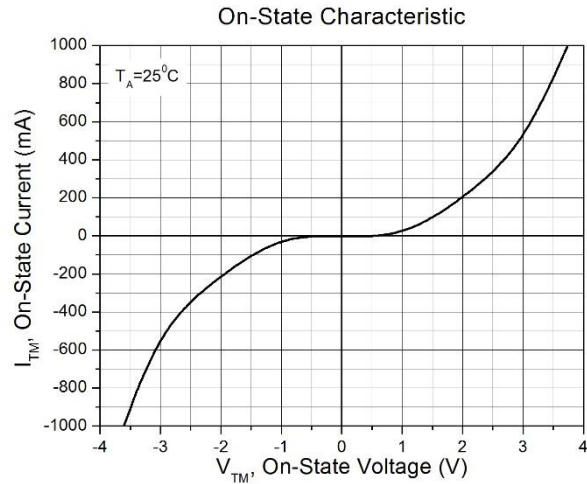

Figure 2

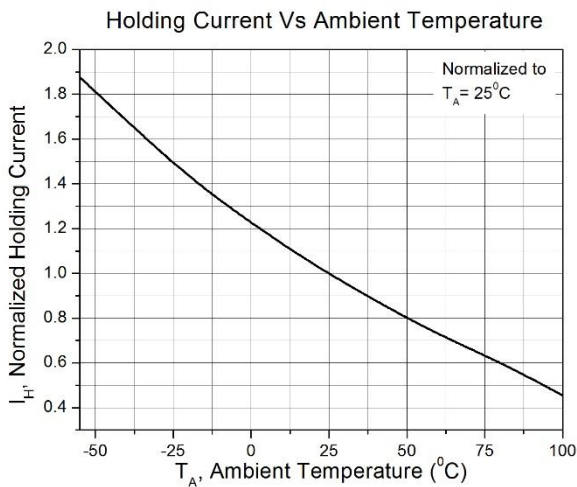

Figure 3

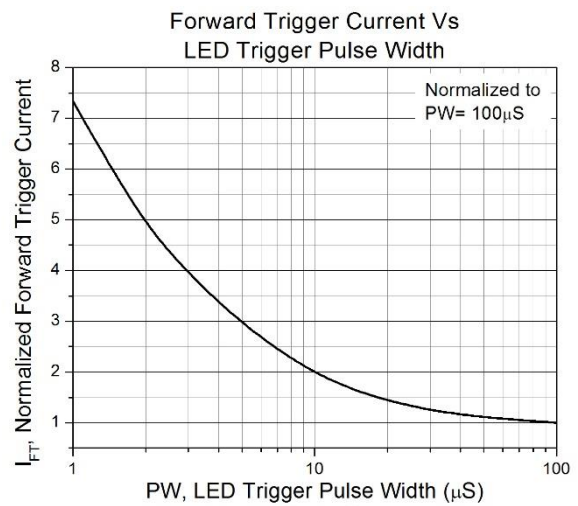

Figure 4

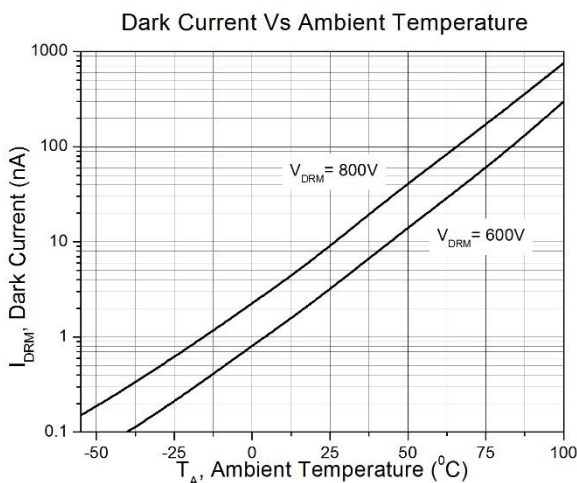

Figure 5

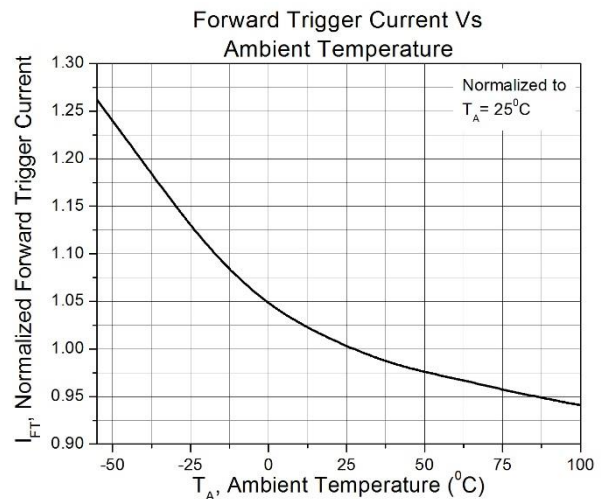

Figure 6



CT303X, CT304X, CT306X, CT308X 6Pin Zero Cross TRIAC Driver Coupler

CT Micro

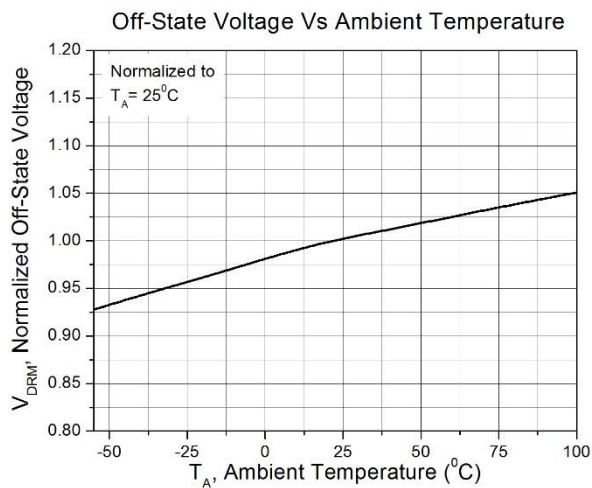

Figure 7

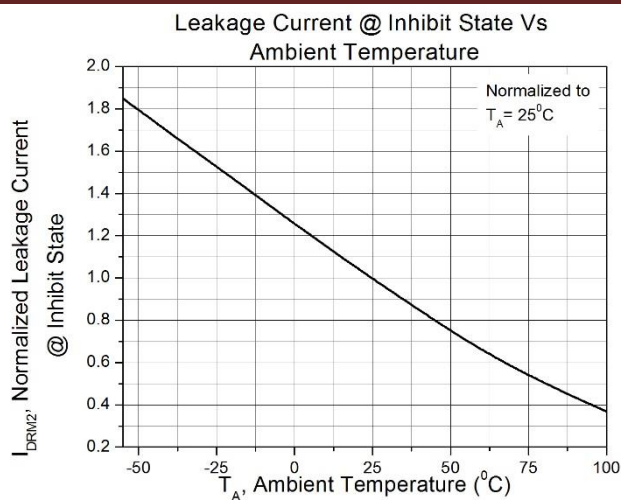

Figure 8

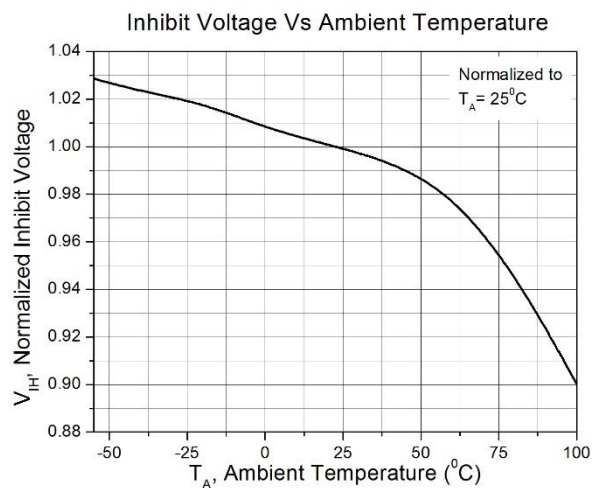

Figure 9



CT303X, CT304X, CT306X, CT308X 6Pin Zero Cross TRIAC Driver Coupler

CT Micro

Package Dimension *Dimensions in mm unless otherwise stated*

Standard DIP – Through Hole

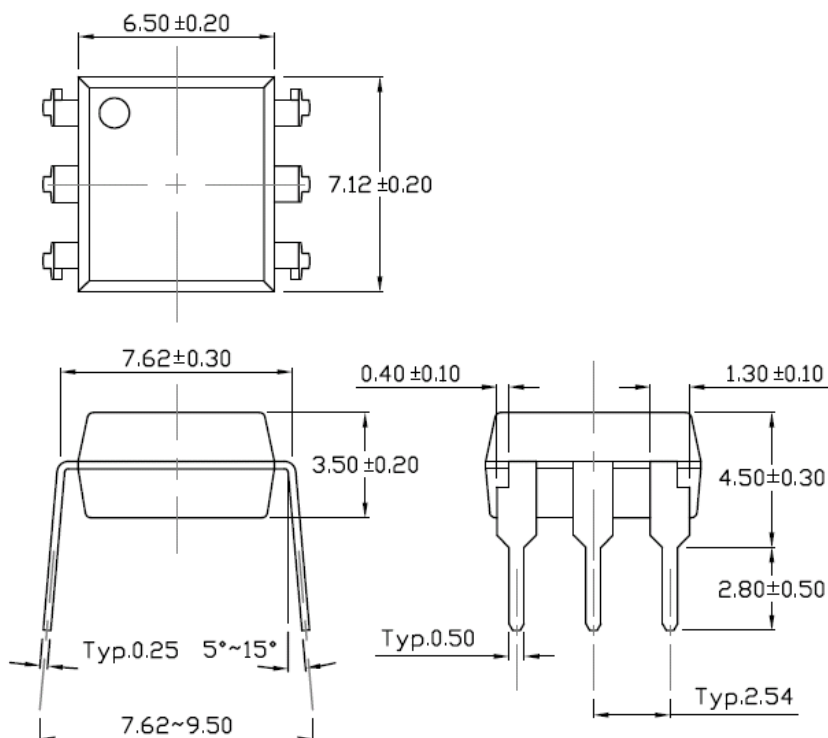

Wide Lead Forming – Through Hole

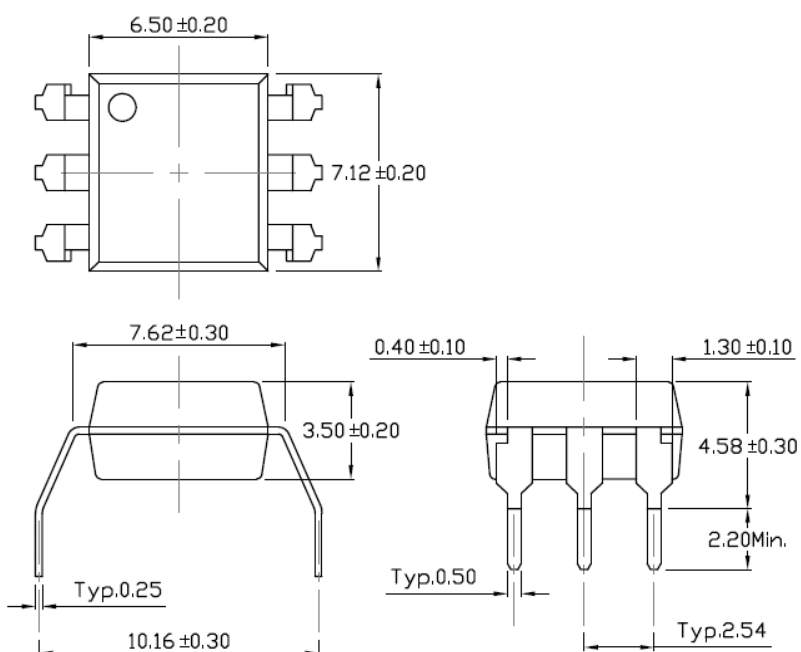



CT303X, CT304X, CT306X, CT308X 6Pin Zero Cross TRIAC Driver Coupler

CT Micro

Surface Mount Forming

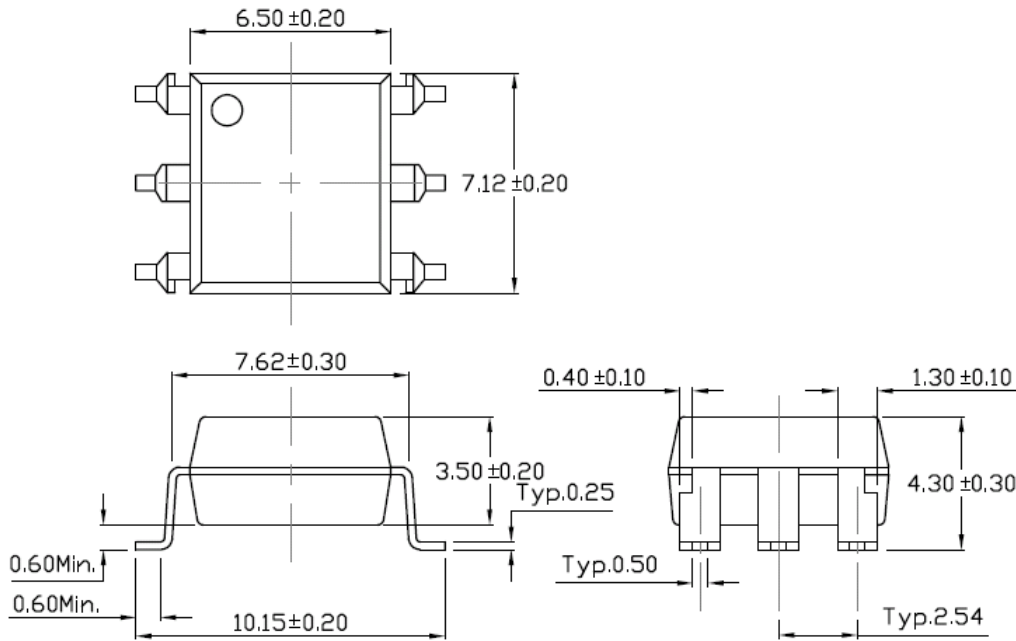

Surface Mount Forming (Low Profile)

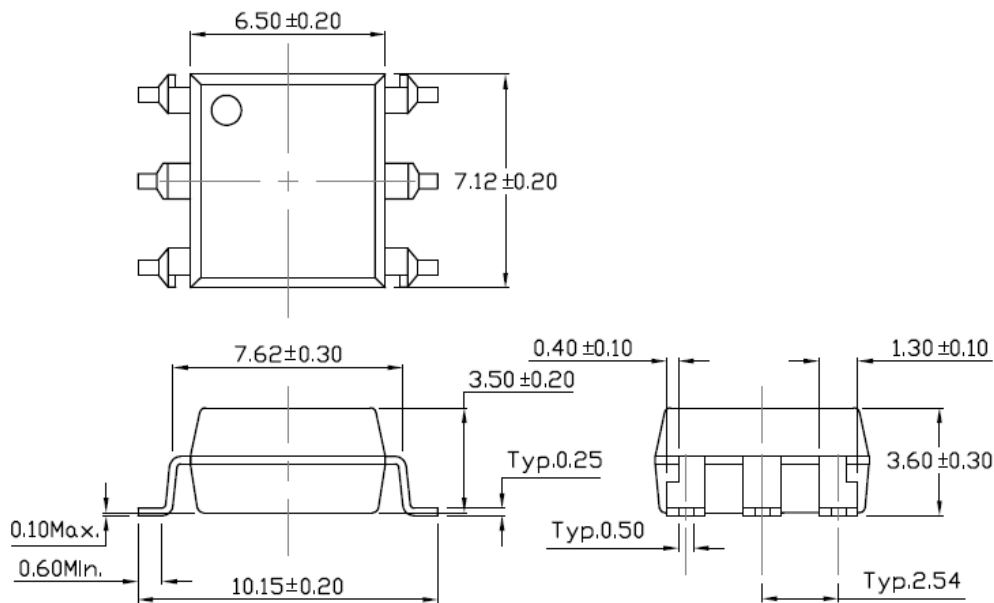



CT303X, CT304X, CT306X, CT308X 6Pin Zero Cross TRIAC Driver Coupler

CT Micro

Recommended Solder Mask *Dimensions in mm unless otherwise stated*

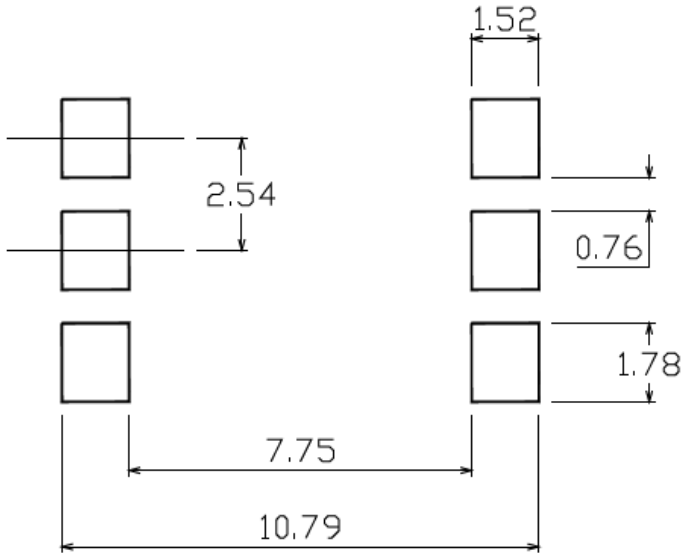

Marking Information

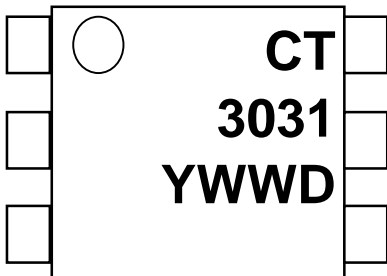

Note:

- CT : Logo
- 3031 : Part Number
- Y : Fiscal Year
- WW : Work Week
- D : Manufacturing Code



CT303X, CT304X, CT306X, CT308X 6Pin Zero Cross TRIAC Driver Coupler

CT Micro

Ordering Information

CT303X(Y)(Z)-G, CT304X(Y)(Z)-G, CT306X(Y)(Z)-G, CT308X(Y)(Z)-G

X = (1,2,3)

Y = Lead form option (S, SL, M or none)

Z = Tape and reel option (TA, TB or none)

G= Material option (G: Green, None: Non-green)

Option	Description	Quantity
None	Standard 6 Pin Dip	50Units/Tube
M	Wide Lead Forming	50Units/Tube
S(TA)	Surface Mount Lead Forming – With Option A Taping	1000 Units/Reel
S(TB)	Surface Mount Lead Forming – With Option B Taping	1000 Units/Reel
SL(TA)	Surface Mount Lead Forming(Low Profile) – With Option A Taping	1000 Units/Reel
SL(TB)	Surface Mount Lead Forming(Low Profile) – With Option B Taping	1000 Units/Reel



CT303X, CT304X, CT306X, CT308X 6Pin Zero Cross TRIAC Driver Coupler

CT Micro

Reflow Profile

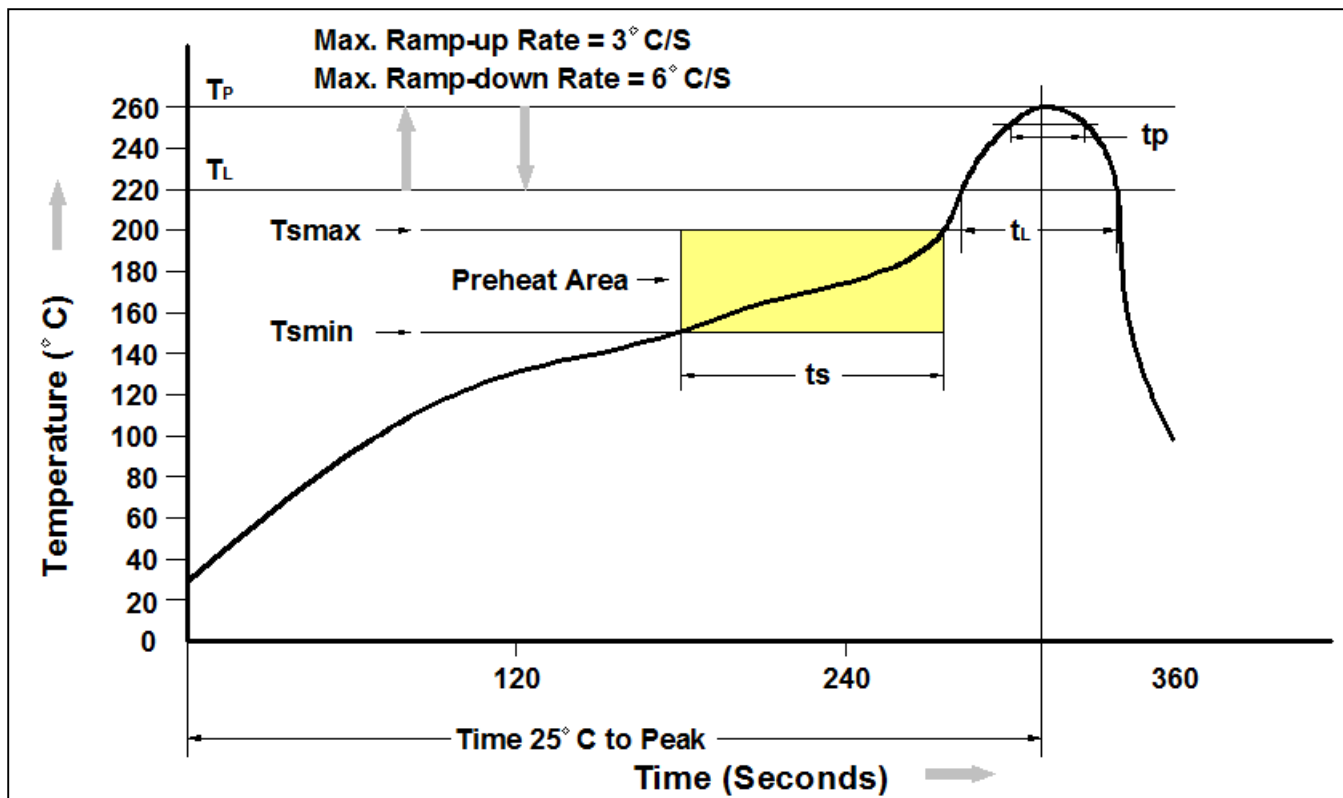

Profile Feature	Pb-Free Assembly Profile
Temperature Min. (T _{smin})	150°C
Temperature Max. (T _{smax})	200°C
Time (t _s) from (T _{smin} to T _{smax})	60-120 seconds
Ramp-up Rate (t _L to t _P)	3°C/second max.
Liquidous Temperature (T _L)	217°C
Time (t _L) Maintained Above (T _L)	60 – 150 seconds
Peak Body Package Temperature	260°C +0°C / -5°C
Time (t _P) within 5°C of 260°C	30 seconds
Ramp-down Rate (T _P to T _L)	6°C/second max
Time 25°C to Peak Temperature	8 minutes max.



CT303X, CT304X, CT306X, CT308X 6Pin Zero Cross TRIAC Driver Coupler

CT Micro

DISCLAIMER

CT MICRO RESERVES THE RIGHT TO MAKE CHANGES WITHOUT FURTHER NOTICE TO ANY PRODUCTS HEREIN TO IMPROVE RELIABILITY, FUNCTION OR DESIGN. CT MICRO DOES NOT ASSUME ANY LIABILITY ARISING OUT OF THE APPLICATION OR USE OF ANY PRODUCT OR CIRCUIT DESCRIBED HEREIN; NEITHER DOES IT CONVEY ANY LICENSE UNDER ITS PATENT RIGHTS, NOR THE RIGHTS OF OTHERS.

DISCOLORATION MIGHT OCCUR ON THE PACKAGE SURFACE AFTER SOLDERING, REFLOW OR LONG TERM USE. THIS DOES NOT IMPACT THE PRODUCT PERFORMANCE NOR THE PRODUCT RELIABILITY.

CT MICRO ARE NOT AUTHORIZED FOR USE AS CRITICAL COMPONENTS IN LIFE SUPPORT DEVICES OR SYSTEMS WITHOUT EXPRESS WRITTEN APPROVAL OF CT MICRO INTERNATIONAL CORPORATION.

- 1. Life support devices or systems are devices or systems which, (a) are intended for surgical implant into the body, or (b) support or sustain life, or (c) whose failure to perform when properly used in accordance with instruction for use provided in the labelling, can be reasonably expected to result in significant injury to the user.*
- 2. A critical component is any component of a life support device or system whose failure to perform can be reasonably expected to cause the failure of the life support device or system, or to affect its safety or effectiveness.*

This datasheet has been downloaded from:

datasheet.eeworld.com.cn

Free Download

Daily Updated Database

100% Free Datasheet Search Site

100% Free IC Replacement Search Site

Convenient Electronic Dictionary

Fast Search System

www.EEworld.com.cn