

LBZX84C12LT1G

S-LBZX84C12LT1G

Zener Voltage Regulator Diodes

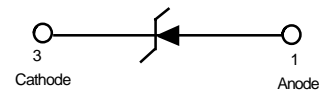
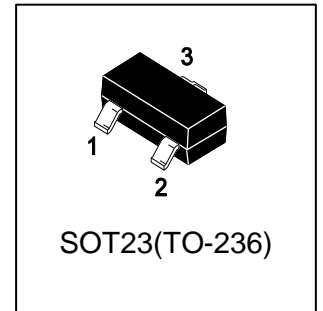

1. FEATURES

- We declare that the material of product compliance with RoHS requirements and Halogen Free.
- S- prefix for automotive and other applications requiring unique site and control change requirements; AEC-Q101 qualified and PPAP capable.

2. DEVICE MARKING AND ORDERING INFORMATION

Device	Marking	Shipping
LBZX84C12LT1G	Y2	3000/Tape&Reel
LBZX84C12LT3G	Y2	10000/Tape&Reel

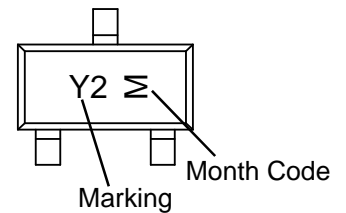

3. THERMAL CHARACTERISTICS

Parameter	Symbol	Limits	Unit
Total Device Dissipation, FR-5 Board (Note 1) @ TA = 25°C Derate above 25°C	PD	225 1.8	mW mW/°C
Thermal Resistance Junction-to-Ambient	RθJA	556	°C/W
Total Device Dissipation, Alumina Substrate (Note 2) @ TA = 25°C Derate above 25°C	PD	300 2.4	mW mW/°C
Thermal Resistance Junction-to-Ambient	RθJA	417	°C/W
Junction and Storage temperature	TJ,Tstg	-55 ~ +150	°C

1.FR-5 = 1.0 × 0.75 × 0.062 in.

2.Alumina = 0.4 × 0.3 × 0.024 in. 99.5% alumina.

4. ELECTRICAL CHARACTERISTICS (Ta= 25°C)

Characteristic	Symbol	Min.	Typ.	Max.	Unit
Zener Voltage(Note 3) (IZT1 = 5 mA) (IZT2 = 1 mA) (IZT3 = 20 mA)	VZ	11.4 11.2 11.4	12 - -	12.7 12.7 12.9	V
Zener Impedance (IZT1 =5mA) (IZT1 =1mA) (IZT1 =20mA)	ZZT	- - -	- - -	25 150 10	Ohm
Reverse Leakage Current (VR=8V)	IR	-	-	0.1	μA
Capacitance (VR=0,f=1MHz)	C	-	130	-	pF
Temperature Coefficient (IZT1 = 5 mA)	θVZ	6	-	10	mV/°C

3.Zener voltage is measured with a pulse test current IZ at an ambient temperature of 25°C.

5.ELECTRICAL CHARACTERISTICS CURVES

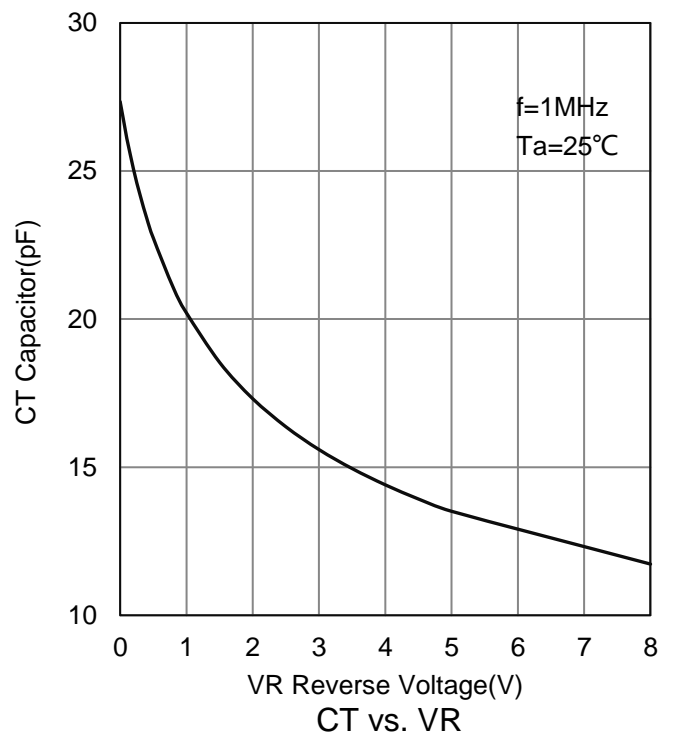
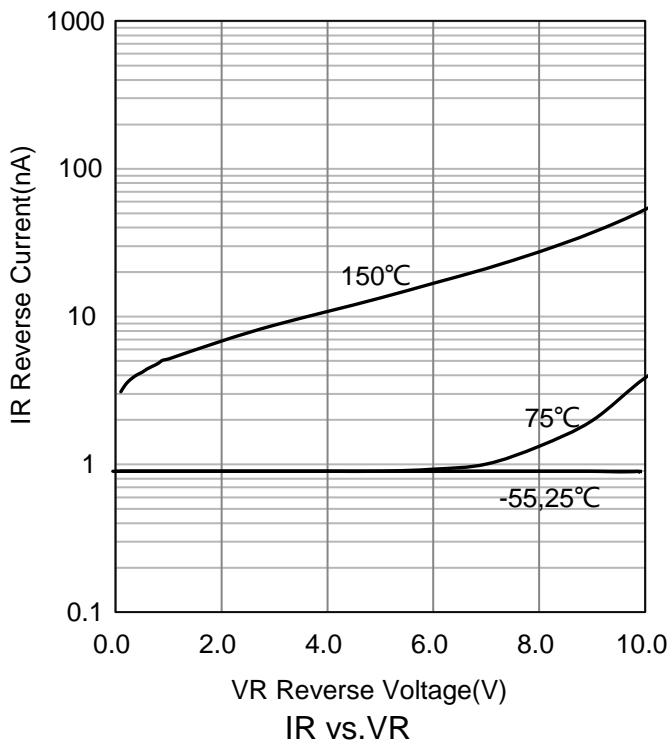
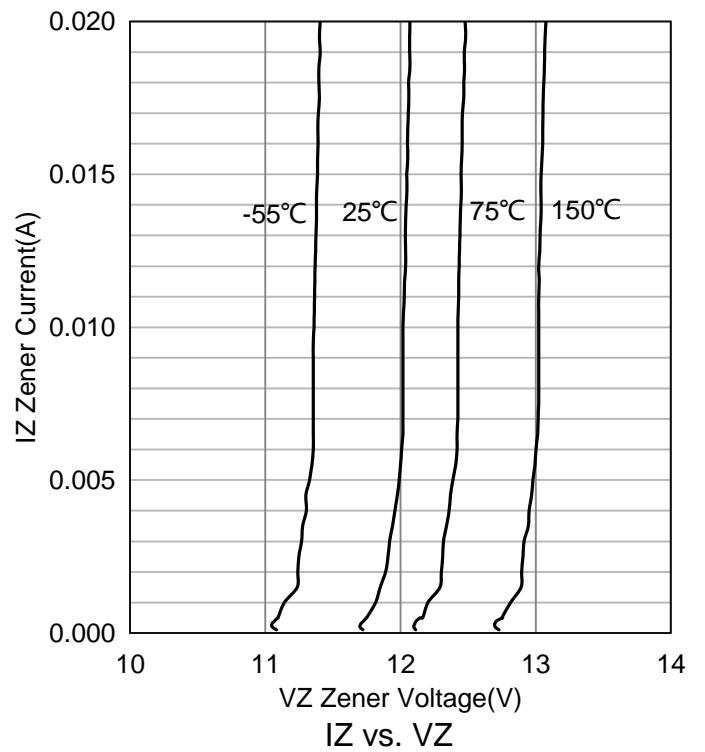
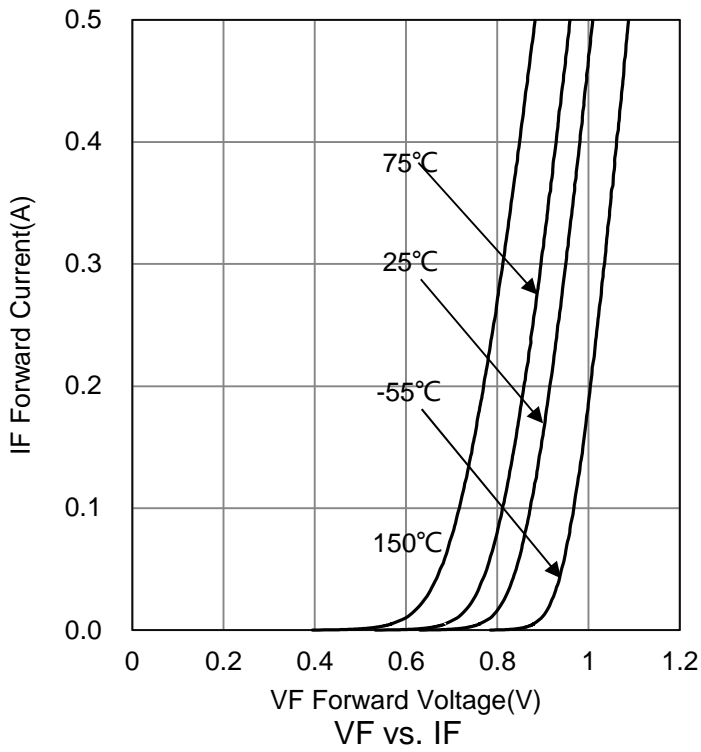

6. OUTLINE AND DIMENSIONS

Notes:

1. DIMENSIONING AND TOLERANCING PER ANSI Y14.5M, 1982.
2. CONTROLLING DIMENSION: MILLIMETERS.
3. MAXIMUM LEAD THICKNESS INCLUDES LEAD FINISH. MINIMUM LEAD THICKNESS IS THE MINIMUM THICKNESS OF BASE MATERIAL.
4. DIMENSIONS D AND E DO NOT INCLUDE MOLD FLASH, PROTRUSIONS OR GATE BURRS.

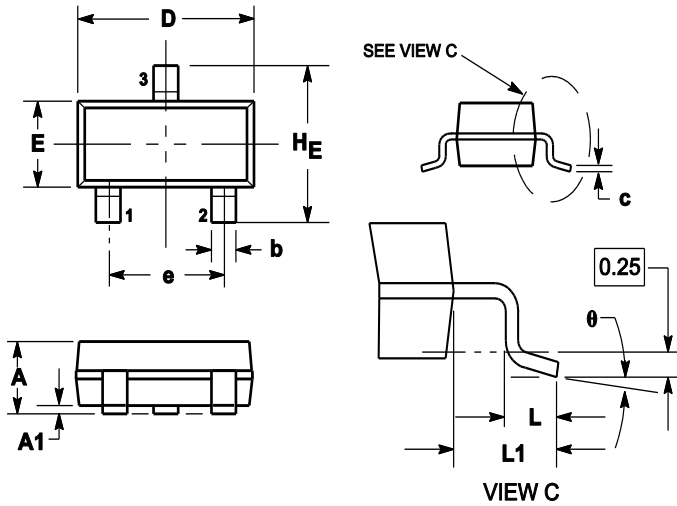

DIM	MILLIMETERS			INCHES		
	MIN	NOM	MAX	MIN	NOM	MAX
A	0.89	1	1.11	0.035	0.04	0.044
A1	0.01	0.06	0.1	0.001	0.002	0.004
b	0.37	0.44	0.5	0.015	0.018	0.02
c	0.09	0.13	0.18	0.003	0.005	0.007
D	2.80	2.9	3.04	0.11	0.114	0.12
E	1.20	1.3	1.4	0.047	0.051	0.055
e	1.78	1.9	2.04	0.07	0.075	0.081
L	0.10	0.2	0.3	0.004	0.008	0.012
L1	0.35	0.54	0.69	0.014	0.021	0.029
HE	2.10	2.4	2.64	0.083	0.094	0.104
θ	0°	---	10°	0°	---	10°

7. SOLDERING FOOTPRINT

