



鑫沃科技
XIN WO TECHNOLOGY



AO3400

N Channel Advanced Power MOSFET
SOT23/30V/5.8A

深圳东为电子科技有限公司
DONGWEI ELECTRONIC TECHNOLOGY CO., LTD

Features

- Low $R_{DS(on)}$ @ $V_{GS}=10V$
- 3.3V Logic Level Control
- N Channel SOT23 Package
- Pb-Free, RoHS Compliant

$V_{(BR)DSS}$	$R_{DS(ON)}$ Typ	I_D Max
30V	26m Ω @10V	5.8A
	31m Ω @ 4.5V	

Applications

- Charging switch for portable devices
- Small brushless DC motor drive
- Load Switch for PWM
- DC-to-DC converters

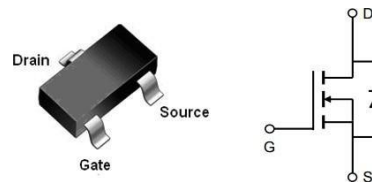
SOT23
Order Information

Product	Package	Marking	Packing	Min Unit Quantity
AO3400	SOT23	A09T	3000PCS/Reel	3000PCS

Absolute Maximum Ratings

Stresses exceeding Maximum Ratings may damage the device. Maximum Ratings are stress ratings only. Functional operation above the Recommended Operating Conditions is not implied. Extended exposure to stresses above the Recommended Operating Conditions may affect device reliability.

Symbol	Parameter	Rating	Unit
Common Ratings (TA=25°C Unless Otherwise Noted)			
V_{GS}	Gate-Source Voltage	± 12	V
$V_{(BR)DSS}$	Drain-Source Breakdown Voltage	30	V
T_J	Maximum Junction Temperature	150	°C
T_{STG}	Storage Temperature Range	-50 to 150	°C
Mounted on Large Heat Sink			
I_{DM}	Pulse Drain Current Tested①	$T_A=25^\circ\text{C}$	23 A
I_D	Continuous Drain Current	$T_A=25^\circ\text{C}$	5.8 A
		$T_A=70^\circ\text{C}$	4.6 A
P_D	Maximum Power Dissipation	$T_A=25^\circ\text{C}$	1.5 W
		$T_A=70^\circ\text{C}$	0.9 W
$R_{\theta JA}$	Thermal Resistance Junction-Ambient	100	°C/W

Symbol	Parameter	Condition	Min	Typ	Max	Unit
Static Electrical Characteristics @ T_J = 25°C (unless otherwise stated)						
V _{(BR)DSS}	Drain-Source Breakdown Voltage	V _{GS} =0V I _D =250μA	30	--	--	V
I _{DSS}	Zero Gate Voltage Drain Current(T _A =25°C)	V _{DS} =30V, V _{GS} =0V	--	--	1	μA
	Zero Gate Voltage Drain Current(T _A =125°C)	V _{DS} =24V, V _{GS} =0V	--	--	100	uA
I _{GSS}	Gate-Body Leakage Current	V _{GS} =±12V, V _{DS} =0V	--	--	±100	nA
V _{GS(TH)}	Gate Threshold Voltage	V _{DS} =V _{GS} , I _D =250μA	0.4	0.8	1.5	V
R _{DS(ON)}	Drain-Source On-State Resistance ^②	V _{GS} =10V, I _D =5A	--	26	33	mΩ
R _{DS(ON)}	Drain-Source On-State Resistance ^②	V _{GS} =4.5V, I _D =4A	--	31	36	mΩ
R _{DS(ON)}	Drain-Source On-State Resistance ^②	V _{GS} =3.3V, I _D =3A	--	45	55	mΩ
Dynamic Electrical Characteristics @ T_J = 25°C (unless otherwise stated)						
C _{iss}	Input Capacitance	V _{DS} =15V, V _{GS} =0V, f=1MHz	--	650	--	pF
C _{oss}	Output Capacitance		--	54	--	pF
C _{rss}	Reverse Transfer Capacitance		--	47	--	pF
Q _g	Total Gate Charge	V _{DS} =15V I _D =5A, V _{GS} =4.5V	--	6.2	--	nC
Q _{gs}	Gate Source Charge		--	1.2	--	nC
Q _{gd}	Gate Drain Charge		--	1.9	--	nC
Switching Characteristics @ T_J = 25°C (unless otherwise stated)						
t _{d(on)}	Turn on Delay Time	V _{DD} =15V, I _D =5A, R _G =3.3Ω, V _{GS} =4.5V	--	7.5	--	ns
t _r	Turn on Rise Time		--	18	--	ns
t _{d(off)}	Turn Off Delay Time		--	36	--	ns
t _f	Turn Off Fall Time		--	5	--	ns
Source Drain Diode Characteristics @ T_J = 25°C (u nless otherwise stated)						
I _{SD}	Source drain current(Body Diode)	T _A =25°C	--	--	1.5	A
V _{SD}	Forward on voltage ^②	T _J =25°C, I _{SD} =5A, V _{GS} =0V	--	0.83	1.2	V

Notes:

- ① Pulse width limited by maximum allowable junction temperature
 ② Pulse test ; Pulse width≤300μs, duty cycle≤2%.

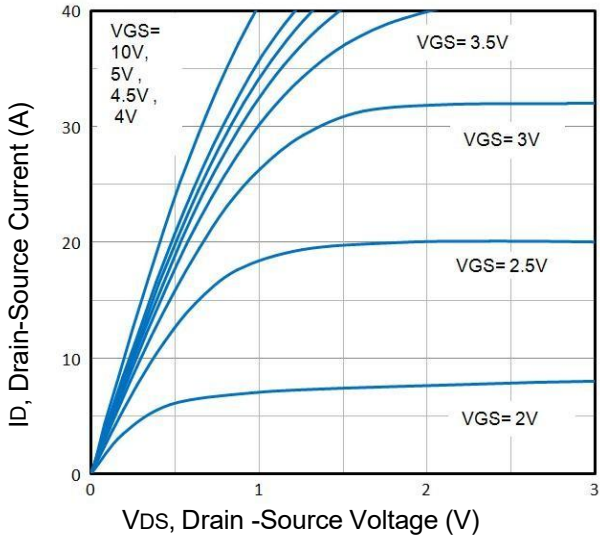

Fig1. Typical Output Characteristics

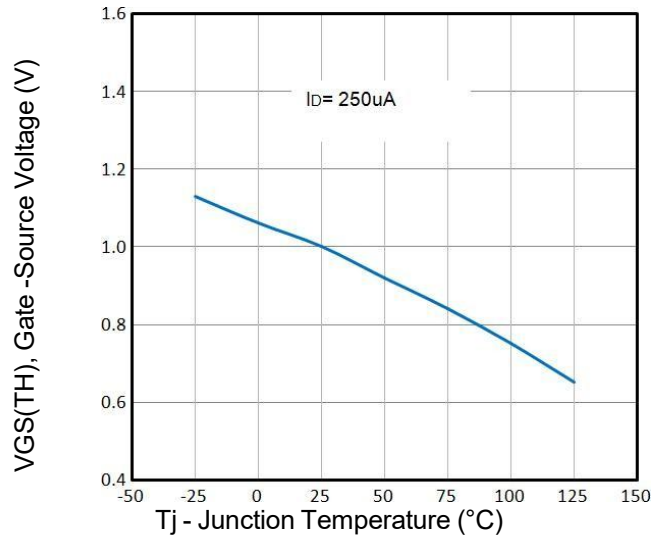

Fig2. Normalized Threshold Voltage Vs. Temperature

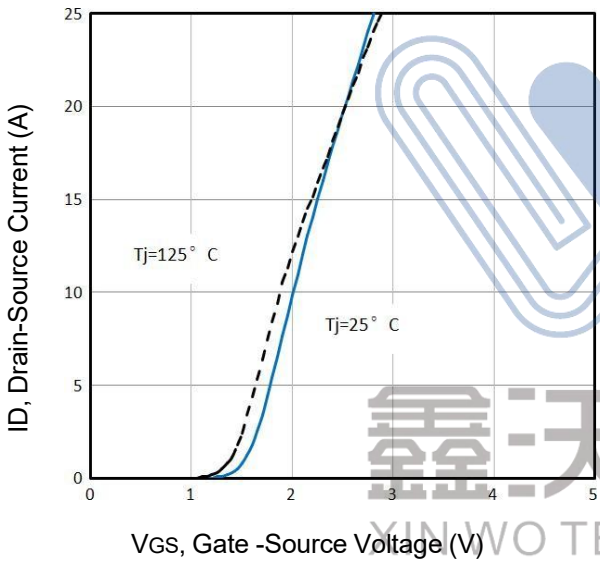

Fig3. Typical Transfer Characteristics

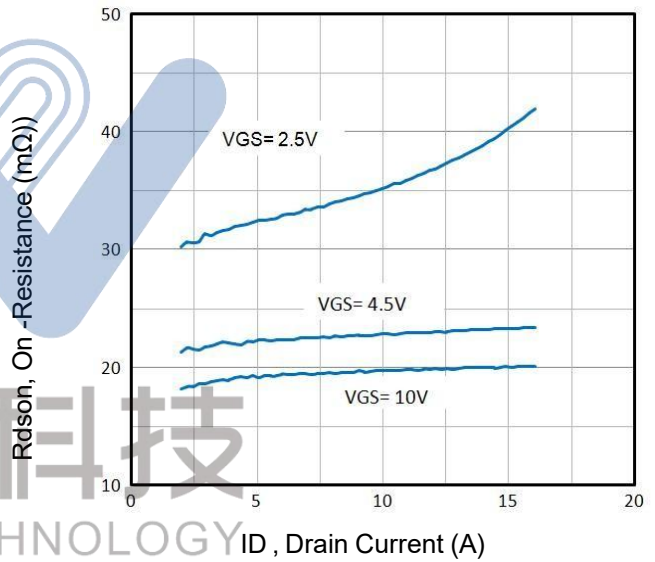

Fig4. On-Resistance vs. Drain Current and VGS

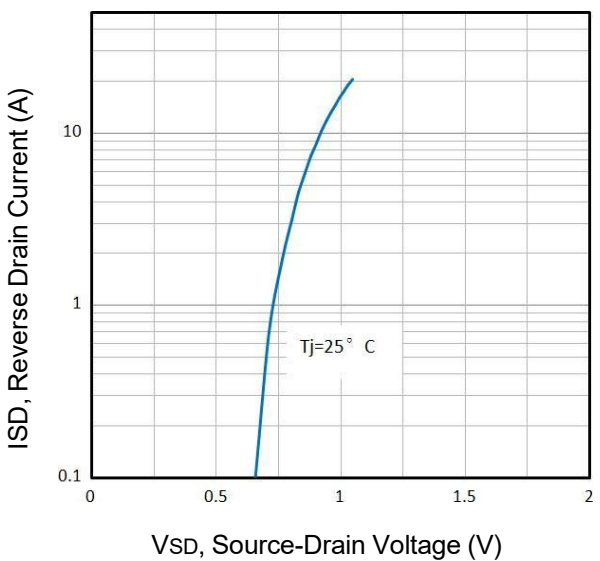

Fig5. Typical Source-Drain Diode Forward Voltage

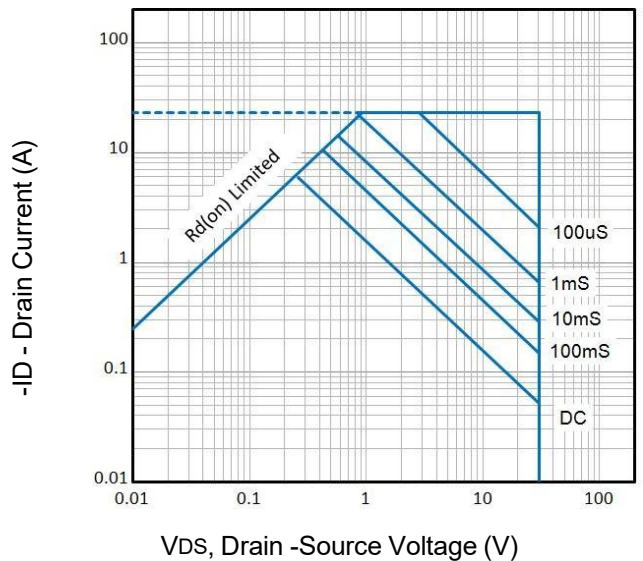

Fig6. Maximum Safe Operating Area

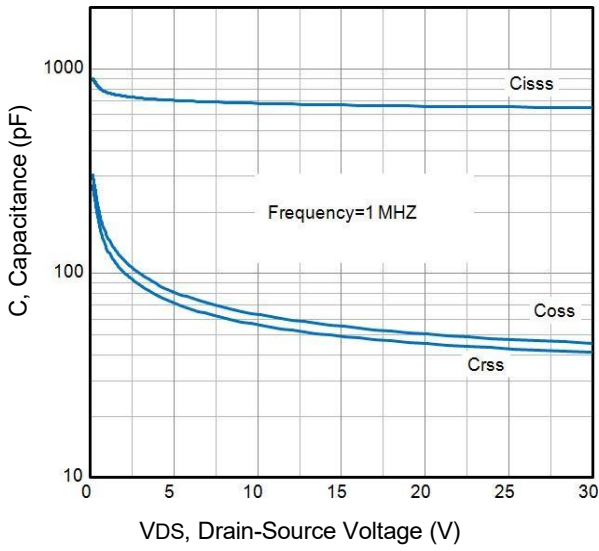

Fig7. Typical Capacitance Vs. Drain-Source Voltage

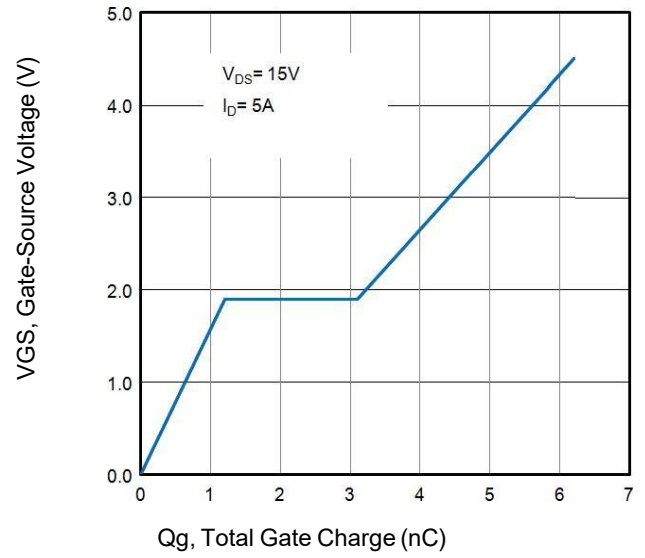

Fig8. Typical Gate Charge Vs. Gate-Source Voltage

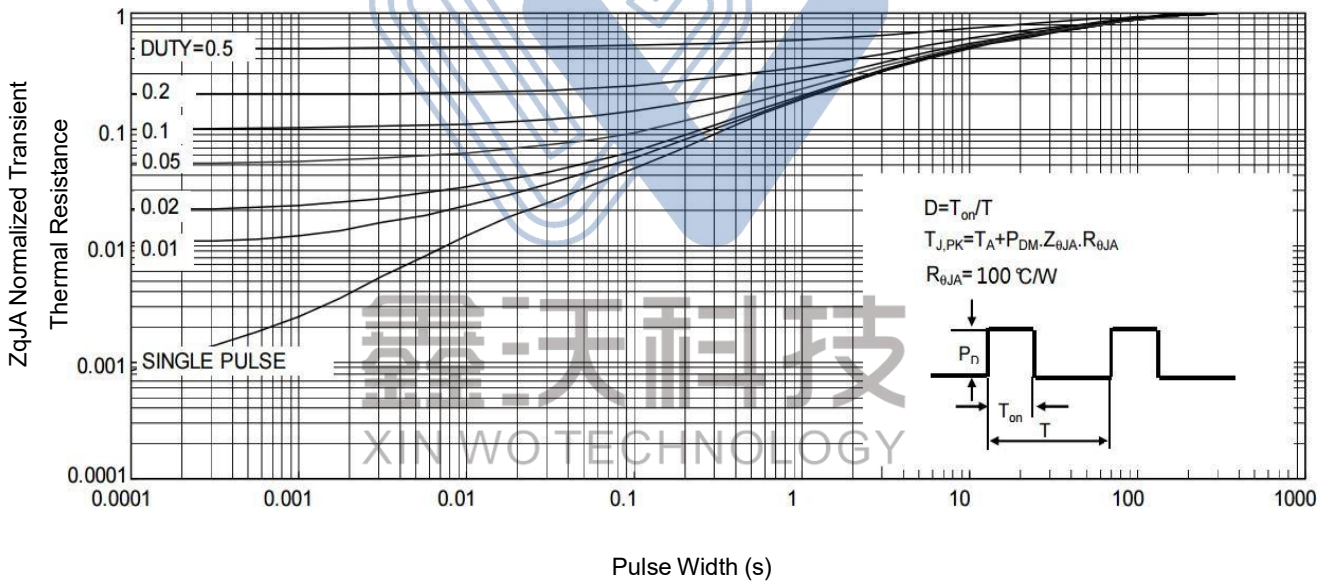

Fig9. Normalized Maximum Transient Thermal Impedance

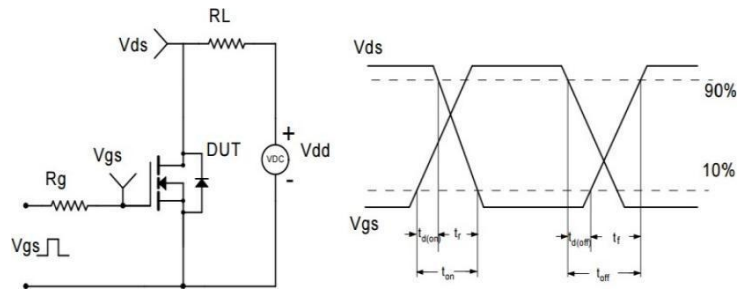
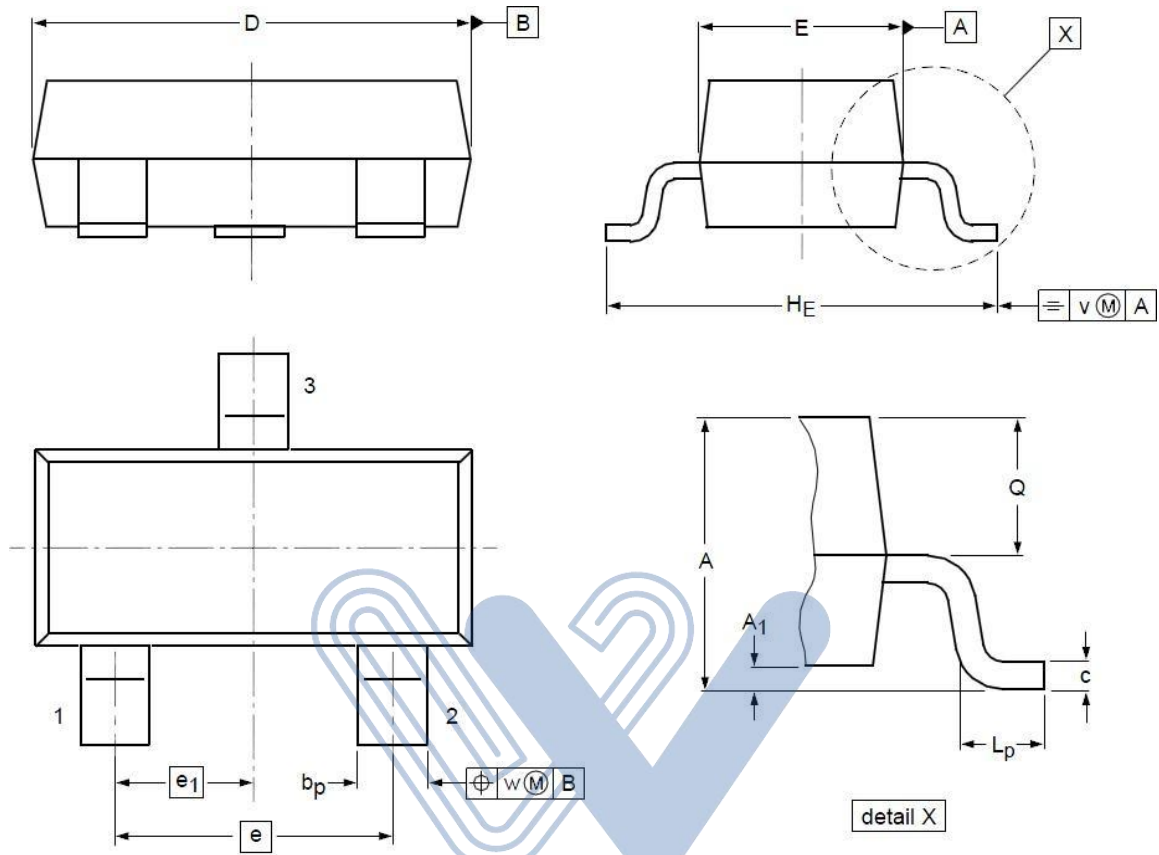

Fig10. Switching Time Test Circuit and waveforms

SOT23 Mechanical Data



DIMENSIONS (unit : mm)

Symbol	Min	Typ	Max	Symbol	Min	Typ	Max
A	0.90	1.01	1.15	A ₁	0.01	0.05	0.10
b _p	0.30	0.42	0.50	c	0.08	0.13	0.15
D	2.80	2.92	3.00	E	1.20	1.33	1.40
e	--	1.90	--	e ₁	--	0.95	--
H _E	2.25	2.40	2.55	L _p	0.30	0.42	0.50
Q	0.45	0.49	0.55	v	--	0.20	--
w	--	0.10	--				