

Features

- ◆ The plastic package carries Underwriters Laboratory Flammability Classification 94V-0
- ◆ Open Junction chip
- ◆ Low reverse leakage
- ◆ High forward surge current capability
- ◆ High temperature soldering guaranteed
250°C/10 seconds at terminals

Mechanical Data

Case : Molded plastic body

Terminals : Solder plated, solderable per MIL-STD-750, Method 2026

Polarity : Polarity symbol marking on body

Mounting Position : Any

Weight : 0.072 ounce, 2.05 grams

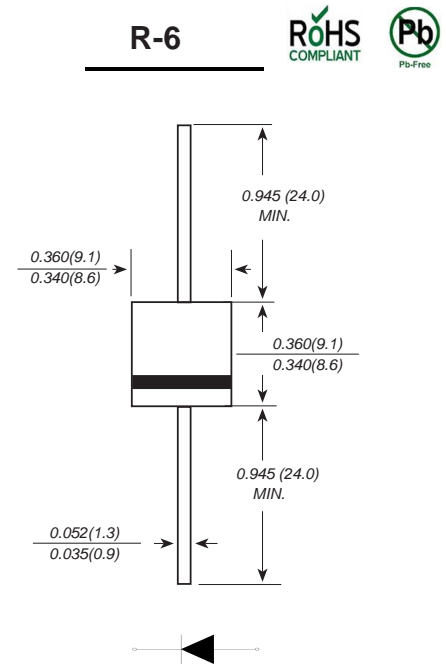

Dimensions in inches and (millimeters)

Maximum Ratings And Electrical Characteristics

Ratings at 25°C ambient temperature unless otherwise specified. Single phase half-wave 60Hz, resistive or inductive load, for capacitive load current derate by 20%.

Parameter	SYMBOLS	10A05	10A1	10A2	10A3	10A4	10A5	10A6	10A8	10A10	UNITS
Maximum repetitive peak reverse voltage	V_{RRM}	50	100	200	300	400	500	600	800	1000	V
Maximum RMS voltage	V_{RMS}	35	70	140	210	280	350	420	560	700	V
Maximum DC blocking voltage	V_{DC}	50	100	200	300	400	500	600	800	1000	V
Maximum average forward rectified current at $T_L=100^\circ\text{C}$	$I_{(AV)}$	10.0									A
Peak forward surge current, 8.3ms single half sine-wave superimposed on rated load	I_{FSM}	400.0									A
Maximum instantaneous forward voltage at 10.0A	V_F	1.10									V
Maximum DC reverse current $T_A=25^\circ\text{C}$ at rated DC blocking voltage $T_A=125^\circ\text{C}$	I_R	10.0 500									μA
Typical junction capacitance (Note1)	C_J	150.0									pF
Typical thermal resistance	R_{qJA}	40.0									$^\circ\text{C/W}$
Operating junction and storage temperature range	T_J, T_{STG}	-55 to +150									$^\circ\text{C}$

Note: 1. Measured at 1MHz and applied reverse voltage of 4.0V D.C.

Ratings And Characteristic Curves

FIG. 1- DERATING CURVE OUTPUT RECTIFIED CURRENT

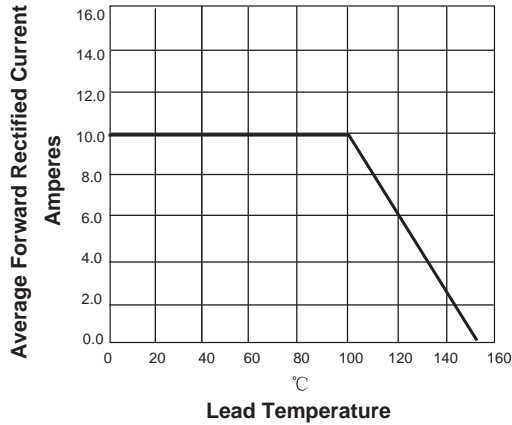

FIG. 2-MAXIMUM NON-REPETITIVE PEAK FORWARD SURGE CURRENT PER LEG

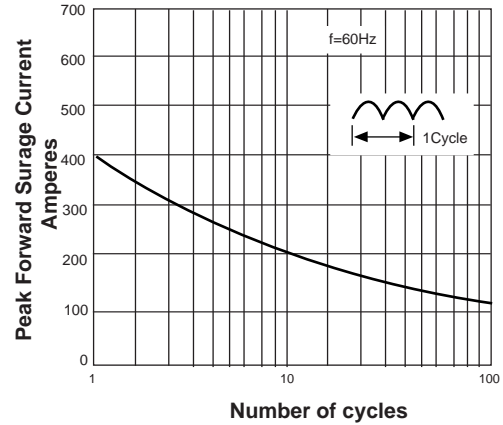

FIG. 3-TYPICAL FORWARD VOLTAGE CHARACTERISTICS

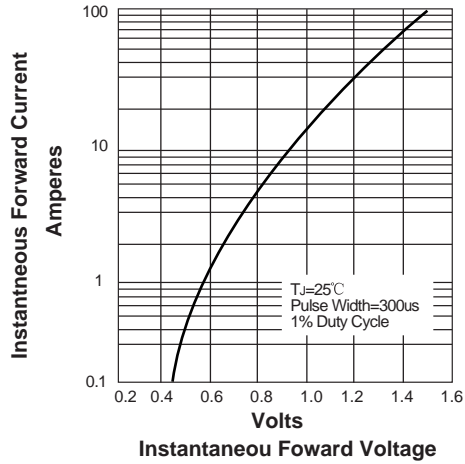
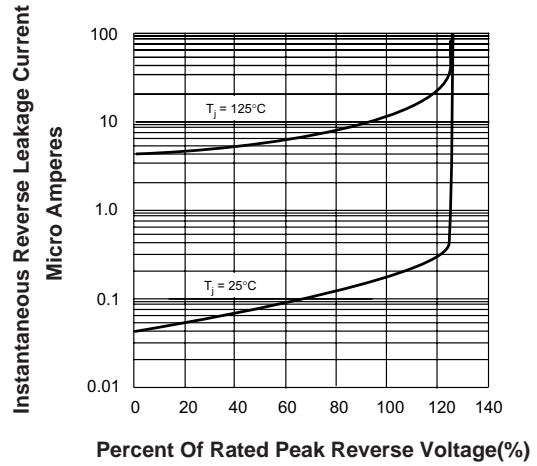
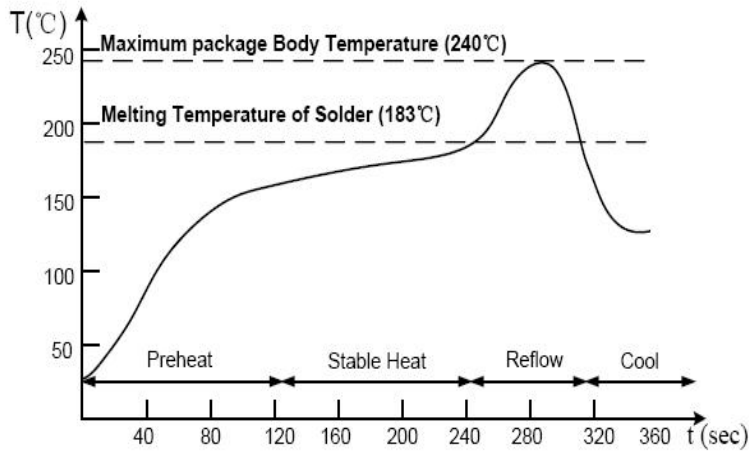

FIG. 4-TYPICAL REVERSE LEAKAGE CHARACTERISTICS



Suggested Soldering Temperature Profile



Note

- ◆ Recommended reflow methods: IR, vapor phase oven, hot air oven, wave solder.
- ◆ The device can be exposed to a maximum temperature of 265°C for 10 seconds.
- ◆ Devices can be cleaned using standard industry methods and solvents.
- ◆ If reflow temperatures exceed the recommended profile, devices may not meet the performance requirements.

Package Information

Taping Specifications

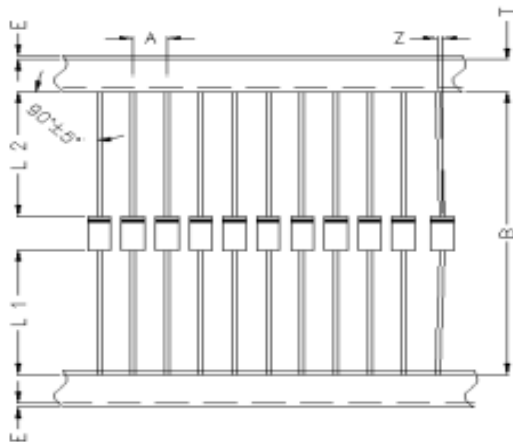

Item	Symbol	Specifications(mm)
Component Pitch	A	10.0±0.5
Inner Tape Pitch	B	52.4±1.5
Component alignment	Z	1.2 Max
Tape width	T	6.0±0.5
Exposed adhesive	E	0.8 Max
Body eccentricity	L1-L2	1.0 Max

Ammunition Package Specifications

Package	Inner Box Size (mm)	QTY/Box (Kpcs)	Carton Size (mm)	Q'TY/Carton (Kpcs)
R - 6	255*150*75	0.5	420*276*312	5.0