

Surface Mount Schottky Barrier Rectifiers

Features

- ◆ Schottky Barrier Chip
- ◆ High Thermal Reliability
- ◆ Patented Super Barrier Rectifier Technology
- ◆ High Forward Surge Capability
- ◆ Ultra Low Power Loss, High Efficiency
- ◆ Excellent High Temperature Stability
- ◆ Plastic material-UL CRKammability 94V-0

Mechanical Data

Case : JEDEC TO-277 Molded plastic body

Terminals : Solder plated, solderable per MIL-STD-750, Method 2026

Polarity : Polarity symbol marking on body

Mounting Position : Any

Weight : 0.003 ounce, 0.0092 grams

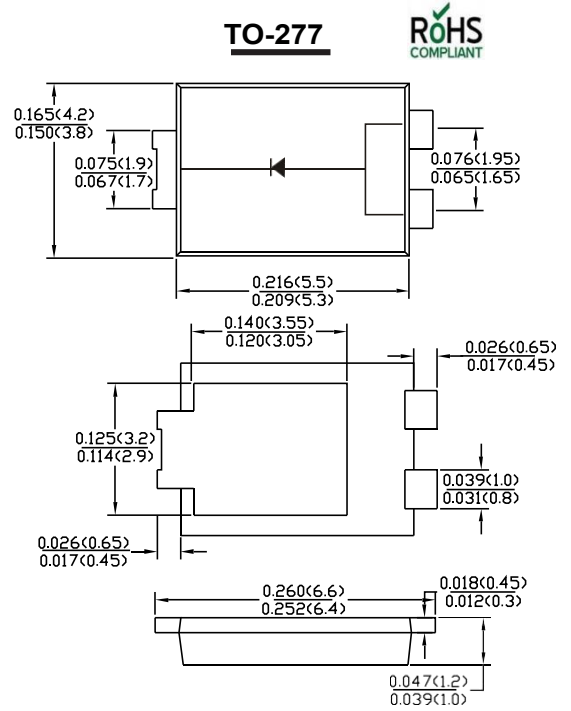

Dimensions in inches and (millimeters)

Maximum Ratings And Electrical Characteristics

Ratings at 25°C ambient temperature unless otherwise specified.

Single phase half-wave 60Hz, resistive or inductive load, for capacitive load current derate by 20%.

| Parameter | SYMBOLS | SR 1045L | SR 1050L | SR 1060L | SR 1080L | SR 10100L | SR 10150L | UNITS |
|--|-----------------|--------------------|--------------------|--------------------|--------------------|---------------------|---------------------|-------|
| | | CRK SR 1045L | CRK SR 1050L | CRK SR 1060L | CRK SR 1080L | CRK SR 10100L | CRK SR 10150L | |
| Maximum repetitive peak reverse voltage | V_{RMM} | 45 | 50 | 60 | 80 | 100 | 150 | V |
| Maximum RMS voltage | V_{RMS} | 32 | 35 | 42 | 56 | 70 | 105 | V |
| Maximum DC blocking voltage | V_{DC} | 45 | 50 | 60 | 80 | 100 | 150 | V |
| Maximum average forward rectified current 0.375"(9.5mm) lead length(see fig.1) (Note1) | $I_{(AV)}$ | 10.0 | | | | | | A |
| Peak forward surge current 8.3ms single half sine-wave superimposed on rated load (JEDEC Method) (Note2) | I_{FSM} | 275.0 | | | | | | A |
| Maximum instantaneous forward voltage at 10.0A | V_F | 0.42 | 0.45 | 0.47 | 0.75 | 0.78 | | V |
| Maximum DC reverse current at rated DC blocking voltage $T_A=25^{\circ}C$ $T_A=100^{\circ}C$ | I_R | 0.3 | | | | | | mA |
| | | 15.0 | | | | | | |
| Typical junction capacitance (NOTE 1) | C_J | 80 | | | | | | pF |
| Typical thermal resistance (NOTE 2) | $R_{\theta JA}$ | 15.0 | | | | | | °C/W |
| Operating junction and storage | T_J | -65 to +150- | | | | | | °C |
| Storage temperature range | T_{STG} | 65 to +150 | | | | | | °C |

Note:1. Valid Provided that are kept at ambient temperature at a distance of 9.5mm from the case.

2. Fr-4pcb.2oz.Copper,minimum recommend pad layout .18.8mm×14.4.Anode pad dimensions 5.6mm×14.4mm.

Fig.1 - Forward Current Derating Curve

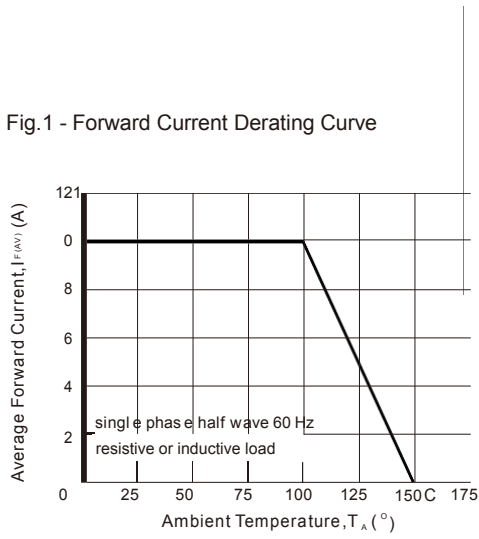

Fig.2 :Instantaneous Forward Voltage

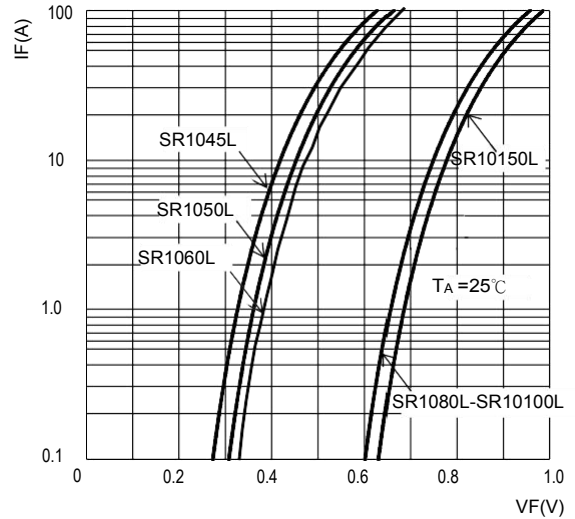

Fig.3: Surge Forward Current Capacity

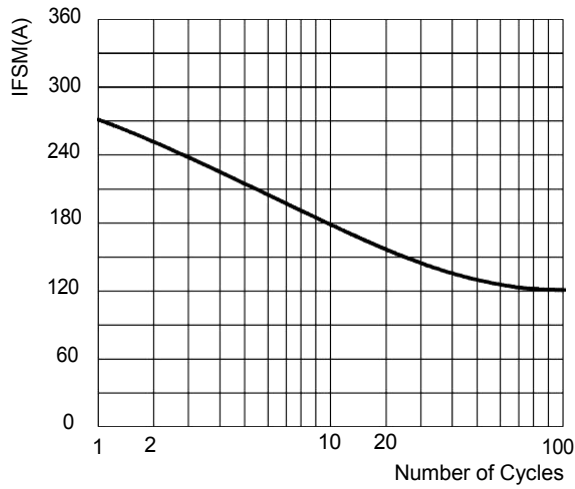

Fig.4: Typical Reverse Characteristics

