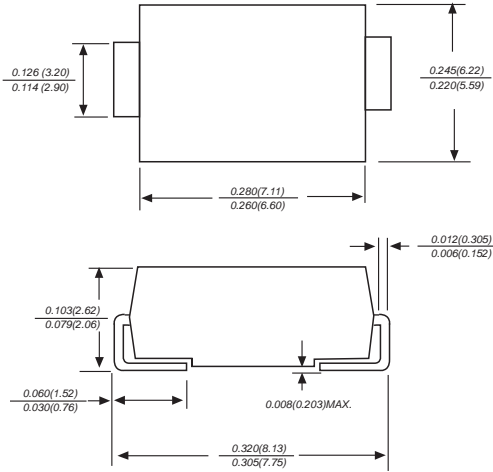

SURFACE MOUNT SUPER FAST RECTIFIER	Reverse Voltage: 50 to 600 Volts Forward Current: 3.0 Amperes
<p style="text-align: center;">DO-214AB/SMC</p>  <p style="text-align: center;"><i>Dimensions in inches and (millimeters)</i></p>	<p>Features</p> <ul style="list-style-type: none"> ◆ The plastic package carries Underwriters Laboratory Flammability Classification 94V-0 ◆ Idea for printed circuit board ◆ Glass passivated Junction chip ◆ Low reverse leakage ◆ High forward surge current capability ◆ High temperature soldering guaranteed 250°C/10 seconds at terminals <p>Mechanical Data</p> <p>Case : Molded plastic body Terminals : Solder plated, solderable per MIL-STD-750, Method 2026 Polarity : Polarity symbol marking on body Mounting Position : Any Weight : 0.008 ounce, 0.225 grams</p>

Maximum Ratings And Electrical Characteristics

Ratings at 25°C ambient temperature unless otherwise specified. Single phase half-wave 60Hz, resistive or inductive load, for capacitive load current derate by 20%.

Parameter	SYMBOLS	ES5AC	ES5BC	ES5CC	ES5DC	ES5FC	ES5GC	ES5JC	UNITS
Maximum repetitive peak reverse voltage	V _{RRM}	50	100	150	200	300	400	600	V
Maximum RMS voltage	V _{RMS}	35	70	105	140	210	280	420	V
Maximum DC blocking voltage	V _{DC}	50	100	150	200	300	400	600	V
Maximum average forward rectified current at T _L =100°C	I _(AV)	5.0							A
Peak forward surge current, 8.3ms single half sine-wave superimposed on rated load	I _{FSM}	150.0							A
Maximum instantaneous forward voltage at 5.0A	V _F	0.95			1.25		1.7		V
Maximum DC reverse current T _A = 25°C at rated DC blocking voltage T _A = 125°C	I _R	5.0 500							uA
Maximum reverse recovery time (Note 1)	T _{rr}	35							ns
Typical junction capacitance (Note 2)	C _J	75.0							pF
Typical thermal resistance	R _{qJA}	47.0							°C/W
Operating junction and storage temperature range	T _J , T _{STG}	-55 to +150							°C

Ratings And Characteristic Curves

FIG. 1- DERATING CURVE OUTPUT RECTIFIED CURRENT

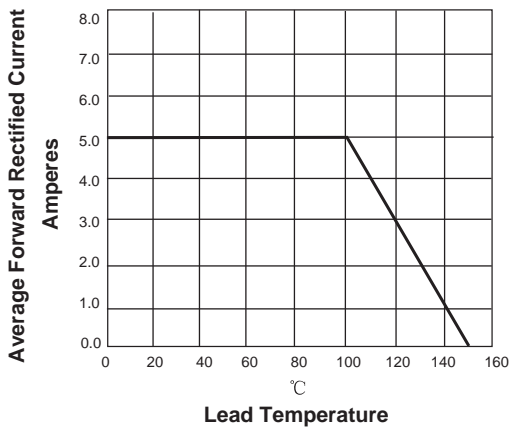

FIG. 2-MAXIMUM NON-REPETITIVE PEAK FORWARD SURGE CURRENT PER LEG

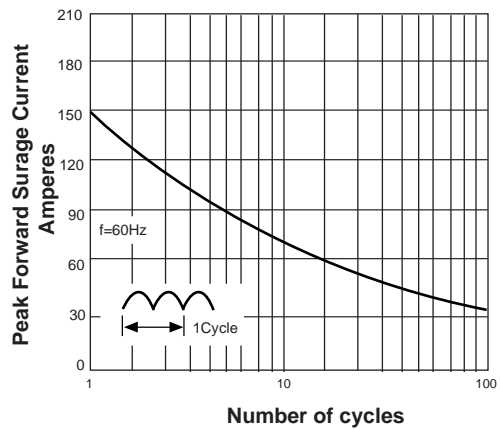

FIG. 3-TYPICAL FORWARD VOLTAGE CHARACTERISTICS

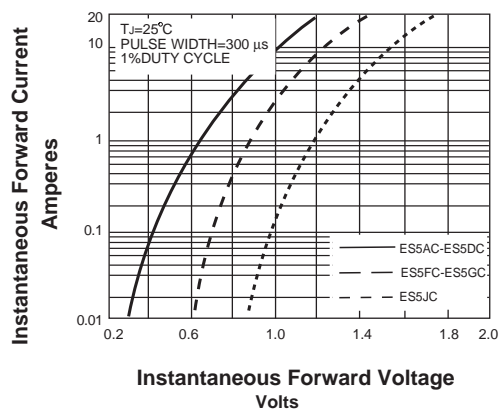

FIG. 4-TYPICAL REVERSE LEAKAGE CHARACTERISTICS

