

SPECIFICATIONS

Customer	
Product Name	Chip NTC Thermistor
Sunlord Part Number	SDNT Series
Customer Part Number	

New Released, Revised]

SPEC No.: SDNT120000

Rev.	Effective Date	Changed Contents	Change Reasons	Approved By
01	/	New release	/	Hai Guo

【This SPEC is total 11 pages including specifications and appendix.】
【ROHS Compliant Parts】

Approved By	Checked By	Issued By

Shenzhen Sunlord Electronics Co., Ltd.

Address: Sunlord Industrial Park, Dafuyuan Industrial Zone, Baoan, Shenzhen, China 518110

Tel: 0086- Fax: 0086

E-Mail:

【For Customer approval Only】

Date: _____

Qualification Status: Full Restricted Rejected

Approved By	Verified By	Re-checked By	Checked By

Comments:

1.

Scope

This specification applies to SDNT series of chip NTC thermistors.

2. Product Description and Identification (Part Number)

1) Description

Example:

SDNT series of multi-layer chip NTC thermistors.

2) Product Identification (Part Number)

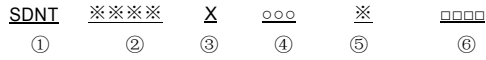

① Type	
SDNT	Chip NTC Thermistor

④ Internal Code	
X	

⑤ Resistance Tolerance	
F	±1%
H	±3%
J	±5%
K	±10%

⑦ B Constant Tolerance	
F	±1%
H	±3%

⑨ HSF Products	
Hazardous Substance-Free Products	

② External Dimensions (L×W) [mm]	
0603 [0201]	0.6×0.3
1005 [0402]	1.0×0.5
1608 [0603]	1.6×0.8
2012 [0805]	2.0×1.25

④ Nominal Zero-Power Resistance (KΩ)	
Example	Nominal Value
103	10
223	22
104	100

⑥ Nominal B Constant (25°C to 50°C)	
Example	Nominal
3450	3450K
4250	4250K

⑧ Packaging	
T	Tape & Reel

3. Electrical Characteristics

Please refer to **Appendix A** (Page 8~11).

- Operating and storage temperature range (individual chip without packing): -55°C ~ +125°C
- Storage temperature range (packing conditions): -10°C~+40°C and RH 75% (Max.)

4. Shape and Dimensions

- Dimensions: See **Fig.4-1** and **Table 4-1**.
- Recommended PCB pattern for reflow soldering: See **Fig.4-2** and **Table 4-1**.

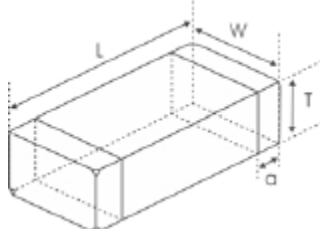

Fig. 4-1

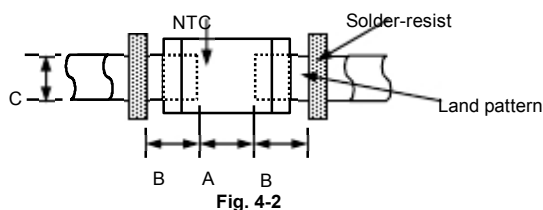

Fig. 4-2

[Table 4-1]

Unit: mm [inch]

Type	L	W	T	a	A	B	C
0603 [0201]	0.6±0.05 [0.024±0.002]	0.3±0.05 [0.012±0.002]	0.3±0.05 [0.012±0.002]	0.15±0.05 [0.006±0.002]	0.20~0.30	0.20~0.30	0.30~0.35
1005 [0402]	1.0±0.15 [0.039±0.006]	0.5±0.15 [0.020±0.006]	0.5±0.15 [0.020±0.006]	0.25±0.1 [0.010±0.004]	0.45~0.55	0.40~0.50	0.45~0.55
1608 [0603]	1.6±0.15 [0.063±0.006]	0.8±0.15 [0.031±0.006]	0.8±0.15 [0.031±0.006]	0.3±0.2 [0.012±0.008]	0.60~0.80	0.60~0.80	0.60~0.80
2012 [0805]	2.0 ±0.2 [0.079 ±0.008]	1.25±0.2 [0.049±0.008]	0.85±0.2 [0.033±0.008]	0.5±0.3 [0.020±0.012]	0.80~ 1.20	0.80~ 1.20	0.90~ 1.60

5.

Test and Measurement Procedures**5.1 Test Conditions**

5.1.1 Unless otherwise specified, the standard atmospheric conditions for measurement/test as:

- a. Ambient Temperature: 20±15℃
- b. Relative Humidity : 65±20%
- c. Air Pressure: 86kPa to 106kPa

5.1.2 If any doubt on the results, measurements/tests should be made within the following limits:

- a. Ambient Temperature: 20±2℃
- b. Relative Humidity: 65±5%
- c. Air Pressure: 86kPa to 106kPa

5.2 Visual Examination

- a. Inspection Equipment: 20× magnifier

5.3 Electrical Test Items	Requirements	Test Methods and Remarks
5.3.1 Nominal Zero-Power Resistance (R25)	Refer to Appendix A	Ambient temperature: 25±0.2℃. Measuring electric power: 0.1mW Max.
5.3.2 Nominal B Constant	Refer to Appendix A	Measure the resistance at the ambient temperature of 25±0.2℃ and 50±0.2℃ $\ln R_{25} - \ln R_{50}$ B= $1/T_{25} - 1/T_{50}$ T: absolute temperature (K)
5.3.3 Thermal Time Constant (single unit)	Refer to Appendix A T ₁ X T ₀ temperature 63.2% Time	The total time for the temperature of the thermistor to change by 63.2% of the difference from ambient temperature T ₀ (°C) to T ₁ (°C) by the drastic change of the power applied to thermistor from Non-zero Power to Zero-Power state.
5.3.4 Dissipation Constant (single unit)	Refer to Appendix A	The total electric power required to raise the temperature of the element by 1℃ through self-heating under thermal equilibrium. It calculates by next formula. $C = \frac{W}{T - T_0}$
5.3.5 Rated Power	Refer to Appendix A	The necessary electric power makes thermistor's temperature rise 100℃ by self-heating at ambient temperature 25℃.
5.3.6 Permissive operating current	Refer to Appendix A	The current that keeps body temperature of chip NTC on the PC board in still air rising 1℃ by self-heating.

5.4 Reliability Test

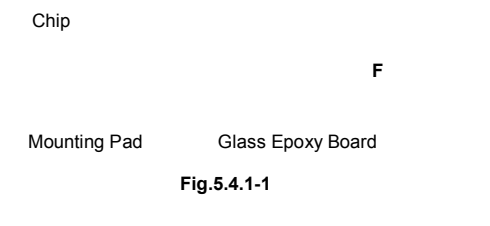
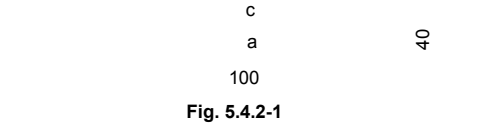
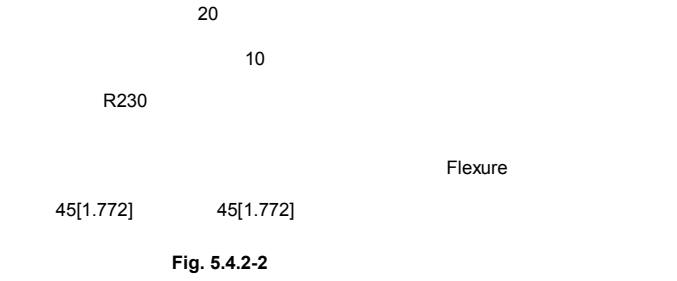
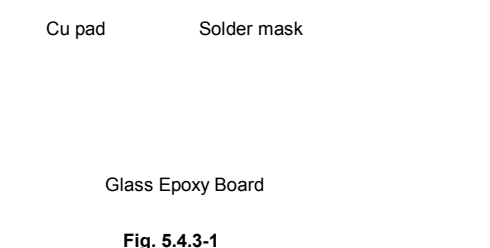
Items	Requirements	Test Methods and Remarks																				
5.4.1. Terminal Strength	No removal or split of the termination or other defects shall occur. 	① Solder the chip to the testing jig (glass epoxy board shown in the following Fig. 5.4.1-1) using eutectic solder. Then apply a force in the direction of the arrow. ② 2N force for 0603 series, 5N force for 1005 and 1608 series, 10N force for 2012 series. ③ Keep time: 10±1s.																				
5.4.2 Resistance to Flexure	No visible mechanical damage. Unit: mm [inch] <table border="1" data-bbox="304 651 767 864"> <thead> <tr> <th>Type</th> <th>a</th> <th>b</th> <th>c</th> </tr> </thead> <tbody> <tr> <td>0603[0201]</td> <td>0.25</td> <td>0.8</td> <td>0.3</td> </tr> <tr> <td>1005[0402]</td> <td>0.4</td> <td>1.5</td> <td>0.5</td> </tr> <tr> <td>1608[0603]</td> <td>1.0</td> <td>3.0</td> <td>1.2</td> </tr> <tr> <td>2012[0805]</td> <td>1.2</td> <td>4.0</td> <td>1.65</td> </tr> </tbody> </table> 	Type	a	b	c	0603[0201]	0.25	0.8	0.3	1005[0402]	0.4	1.5	0.5	1608[0603]	1.0	3.0	1.2	2012[0805]	1.2	4.0	1.65	① Solder the chip to the test jig (glass epoxy board shown in Fig. 5.4.2-1) using a eutectic solder. Then apply a force in the direction shown in Fig. 5.4.2-2 . ② Flexure: 2mm. ③ Pressurizing Speed: 0.5mm/sec. ④ Keep time: 30 sec. 
Type	a	b	c																			
0603[0201]	0.25	0.8	0.3																			
1005[0402]	0.4	1.5	0.5																			
1608[0603]	1.0	3.0	1.2																			
2012[0805]	1.2	4.0	1.65																			
5.4.3 Vibration	No visible mechanical damage. 	① Solder the chip to the testing jig (glass epoxy board shown in Fig. 5.4.3-1) using eutectic solder. ② The chip shall be subjected to a simple harmonic motion having total amplitude of 1.5mm, the frequency being varied uniformly between the approximate limits of 10 and 55 Hz. ③ The frequency ranging from 10 to 55 Hz and returning to 10 Hz shall be traversed in approximately 1 minute. This motion shall be applied for a period of 2 hours in each 3 mutually perpendicular directions (total of 6 hours).																				
5.4.4 Dropping	① No visible mechanical damage.	Drop chip inductor 10 times on a concrete floor from a height of 100 cm.																				
5.4.5 Solderability	① No visible mechanical damage. ② Wetting shall exceed 80% coverage.	① Solder temperature: 240±2℃. ② Duration: 3 sec. ③ Solder: Sn/3.0Ag/0.5Cu. ④ Flux: 25% Resin and 75% ethanol in weight.																				
5.4.6 Resistance to Soldering Heat	① No visible mechanical damage. ② R25 change: within ±5%. ③ B Constant change: within ±2%.	① Solder temperature: 260±3℃ ② Duration: 5 sec. ③ Solder: Sn/3.0Ag/0.5Cu. ④ Flux: 25% Resin and 75% ethanol in weight. ⑤ The chip shall be stabilized at normal condition for 1~2 hours before measuring.																				

<p>5.4.7 Thermal Shock</p>	<p>① No visible mechanical damage. ② R25 change: within $\pm 5\%$. .^{*1} ③ B Constant change: within $\pm 2\%$. .^{*2}</p> <p style="text-align: center;">30 min. 30 min.</p> <p style="text-align: center;">125°C</p> <p>Ambient Temperature</p> <p style="text-align: center;">-55°C 30 min.</p> <p style="text-align: center;">Fig. 5.4.7-1 20sec. (max.)</p>	<p>① Temperature, Time: -55°C for 30±3 min→125°C for 30±3min. ② Transforming interval: 20sec. Max. ③ Tested cycle: 100 cycles. ④ The chip shall be stabilized at normal condition for 1~2 hours before measuring.</p>
<p>5.4.8 Resistance to Low Temperature</p>	<p>① No visible mechanical damage. ② R25 change: within $\pm 5\%$. .^{*1} ③ B Constant change: within $\pm 2\%$. .^{*2}</p>	<p>① Temperature: -55±2°C ② Duration: 1000⁺²⁴ hours. ③ The chip shall be stabilized at normal condition for 1~2 hours before measuring.</p>
<p>5.4.9 Resistance to High Temperature</p>	<p>① No visible mechanical damage. ② R25 change: within $\pm 5\%$. .^{*1} ③ B Constant change: within $\pm 2\%$. .^{*2}</p>	<p>① Temperature: 125±2°C ② Duration: 1000⁺²⁴ hours. ③ The chip shall be stabilized at normal condition for 1~2 hours before measuring.</p>
<p>5.4.10 Damp Heat (Steady States)</p>	<p>① No visible mechanical damage. ② R25 change: within $\pm 5\%$. .^{*1} ③ B Constant change: within $\pm 2\%$. .^{*2}</p>	<p>① Temperature: 60±2°C ② Humidity: 90% to 95% RH. ③ Duration: 1000⁺²⁴ hours. ④ The chip shall be stabilized at normal condition for 1~2 hours before measuring.</p>
<p>5.4.11 Loading at High Temperature (Life Test)</p>	<p>① No visible mechanical damage. ② R25 change: Within $\pm 5\%$. .^{*1} ③ B constant change: Within $\pm 2\%$. .^{*2}</p>	<p>① Temperature: 85±2°C ② Duration: 1000⁺²⁴ hours. ③ Applied current: Max. Permissive Operating Current. ④ The chip shall be stabilized at normal condition for 1~2 hours before measuring.</p>

*1: For F and H tolerance code, the change of R25 should be within $\pm 1\%$ and $\pm 3\%$ respectively. For others, the change of R25 should be within $\pm 5\%$.

*2: For F code tolerance, the change of B constant should be within $\pm 1\%$. For others, the change of B constant should be within $\pm 2\%$.

6. Packaging, Storage and Transportation

6.1 Packaging

6.1.1 Tape Carrier Packaging:

Packaging code: T

- a. Tape carrier packaging are specified in attached figure Fig.6.1-1~4
- b. Tape carrier packaging quantity please see the following table:

Type	0603[0201]	1005[0402]	1608[0603]	2012[0805]
T(mm)	0.3±0.05	0.5±0.15	0.8±0.15	0.85±0.2
Tape	Paper Tape	Paper Tape	Paper Tape	Paper Tape
Quantity	15K	10K	4K	4K

(1). Taping Drawings (Unit: mm)

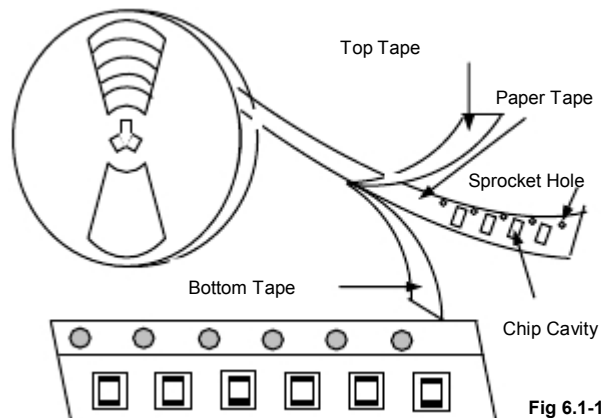
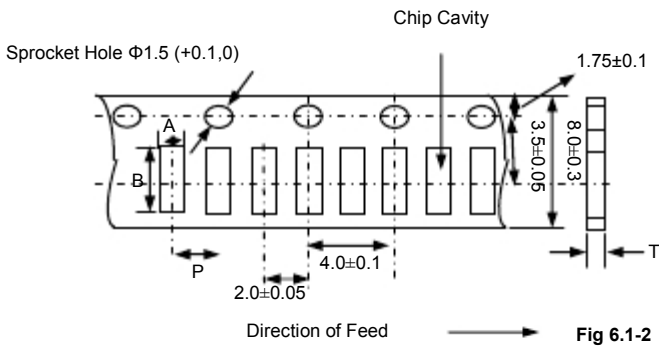

Fig 6.1-1

Remark: The sprocket holes are to the right as the tape is pulled toward the user.

(2) Taping Dimensions (Unit: mm)



Type	A	B	P	Tmax
0603[0201]	0.40 ± 0.1	0.70 ± 0.1	2.0 ± 0.05	0.55
1005[0402]	0.65 ± 0.1	1.15 ± 0.1	2.0 ± 0.05	0.8

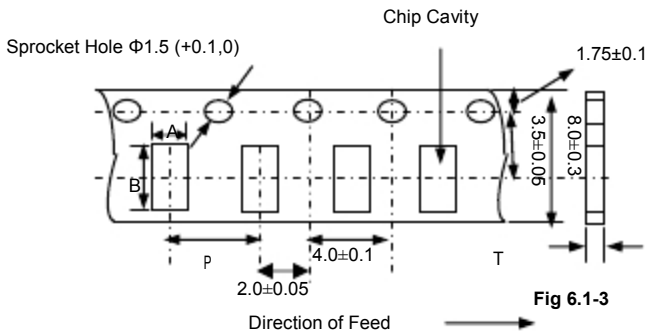

Type	A	B	P	Tmax
1608[0603]	1.0 ± 0.2	1.8 ± 0.2	4.0 ± 0.1	1.1
2012[0805]	1.5 ± 0.2	2.3 ± 0.2	4.0 ± 0.1	1.1

(3) Reel Dimensions (Unit: mm)

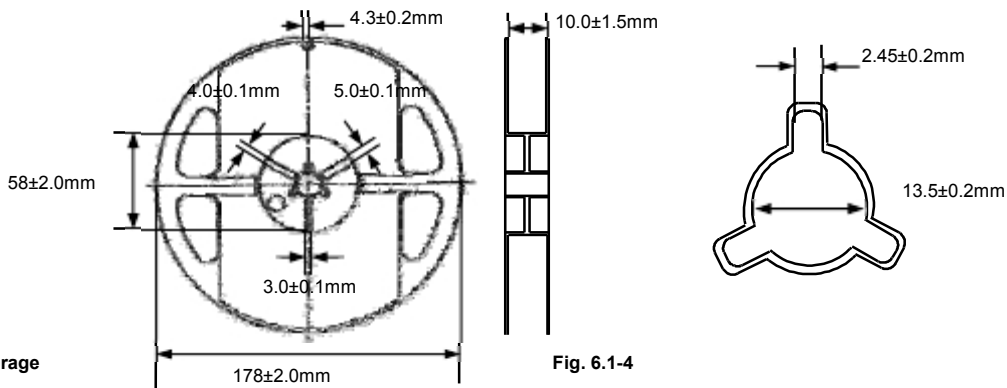

6.2 Storage

- The solderability of the external electrode may be deteriorated if packages are stored where they are exposed to high humidity. Package must be stored at 40°C or less and 70% RH or less.
- The solderability of the external electrode may be deteriorated if packages are stored where they are exposed to dust of harmful gas (e.g. HCl, sulfurous gas of H_2S)
- Packaging material may be deformed if package are stored where they are exposed to heat of direct sunlight.
- Solderability specified in **Clause 5.4.6** shall be guaranteed for 3 months from the date of delivery on condition that they are stored at the environment specified in **Clause 3**. For those parts, which passed more than 3 months shall be checked solder-ability before use.

7. Recommended Soldering Technologies

7.1 Re-flowing Profile:

- Δ Preheat condition: $150 \sim 200^\circ\text{C}/60 \sim 120\text{sec}$.
- Δ Allowed time above 217°C : $60 \sim 90\text{sec}$.
- Δ Max temp: 260°C
- Δ Max time at max temp: 10sec.
- Δ Solder paste: Sn3.0Ag/0.5Cu
- Δ Allowed Reflow time: 2x max

[Note: The reflow profile in the above table is only for qualification and is not meant to specify board assembly profiles. Actual board assembly profiles must be based on the customer's specific board design, solder paste and process, and should not exceed the parameters as the Reflow profile shows.]

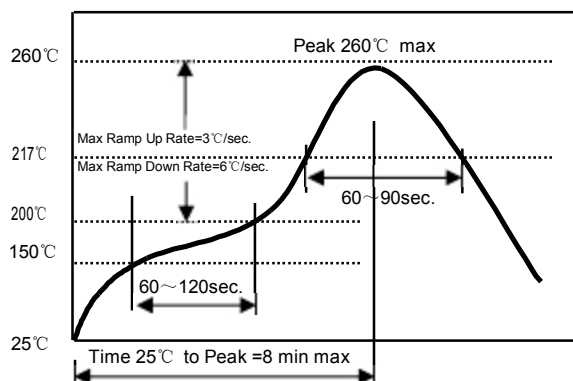

7.2 Iron Soldering Profile.

- △ Iron soldering power: Max.30W
- △ Pre-heating: 150 °C / 60 sec.
- △ Soldering Tip temperature: 350°C Max.
- △ Soldering time: 3 sec Max.
- △ Solder paste: Sn/3.0Ag/0.5Cu
- △ Max.1 times for iron soldering

[Note: Take care not to apply the tip of the soldering iron to the terminal electrodes.]

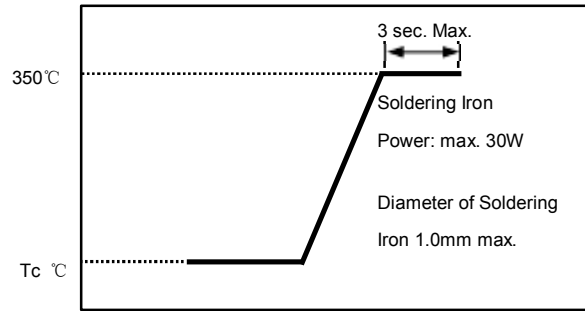
**8. Supplier Information**

- a) Supplier:
Shenzhen Sunlord Electronics Co., Ltd.
- b) Manufacturer:
Shenzhen Sunlord Electronics Co., Ltd.
- c) Manufacturing Address:
Sunlord Industrial Park, Dafuyuan Industrial Zone, Guanlan, Shenzhen, China
Zip: 518110

Appendix A: Electrical Characteristics

I. SDNT0603 Series

Part Number	Resistance at 25°C R25 (kΩ)	B constant (25-50°C) (K)	Max. Permissive Operating Current (25°C) (mA)	Thermal Time Constant	Dissipation Factor (mW/°C)	Rated Electric Power (mW)
SDNT0603X103□3380◎TF	10	3380	0.31	<3sec	1.0	100
SDNT0603X683□4150◎TF	68	4150	0.11			
SDNT0603X104□4150◎TF	100	4150	0.10			

II. SDNT1005 Series

Part Number	Resistance at 25°C R25 (kΩ)	B constant (25-50°C) (K)	Max. Permissive Operating Current (25°C) (mA)	Thermal Time Constant	Dissipation Factor (mW/°C)	Rated Electric Power (mW)
SDNT1005X220□3380◎TF	0.022	3380	6.7	<3sec	1.0	100
SDNT1005X400□3380◎TF	0.040	3380	5.0			
SDNT1005X101□3380◎TF	0.10	3380	3.1			
SDNT1005X151□3380◎TF	0.15	3380	2.5			
SDNT1005X221□3450◎TF	0.22	3450	2.1			
SDNT1005X331□3450◎TF	0.33	3450	1.7			
SDNT1005X471□3450◎TF	0.47	3450	1.4			
SDNT1005X681□3450◎TF	0.68	3450	1.2			
SDNT1005X102□3450◎TF	1.0	3450	1.0			
SDNT1005X152□3950◎TF	1.5	3950	0.81			
SDNT1005X222□3950◎TF	2.2	3950	0.67			
SDNT1005X332□3950◎TF	3.3	3950	0.55			
SDNT1005X472□3950◎TF	4.7	3950	0.46			
SDNT1005X682□3950◎TF	6.8	3950	0.38			
SDNT1005X103□3380◎TF	10	3380	0.31			
SDNT1005X103□3950◎TF	10	3950	0.33			
SDNT1005X103□4050◎TF	10	4050	0.33			
SDNT1005X153□3450◎TF	15	3450	0.25			
SDNT1005X223□3950◎TF	22	3950	0.23			
SDNT1005X333□3500◎TF	33	3500	0.14			
SDNT1005X473□4100◎TF	47	4100	0.12			
SDNT1005X503□4100◎TF	50	4100	0.12			
SDNT1005X683□4150◎TF	68	4150	0.11			
SDNT1005X104□4150◎TF	100	4150	0.10			
SDNT1005X104□4250◎TF	100	4250	0.10			
SDNT1005X154□4150◎TF	150	4150	0.08			
SDNT1005X224□4250◎TF	220	4250	0.06			
SDNT1005X334□4300◎TF	330	4300	0.05			
SDNT1005X474□4350◎TF	470	4350	0.04			
SDNT1005X684□4400◎TF	680	4400	0.03			

III. SDNT1608 Series

Part Number	Resistance at 25°C R25 (kΩ)	B constant (25-50°C) (K)	Max. Permissive Operating Current (25°C) (mA)	Thermal Time Constant	Dissipation Factor (mW/°C)	Rated Electric Power (mW)
SDNT1608X101□3380◎TF	0.10	3380	3.1	<5sec	1.0	100
SDNT1608X151□3380◎TF	0.15	3380	2.5			
SDNT1608X221□3450◎TF	0.22	3450	2.1			
SDNT1608X331□3450◎TF	0.33	3450	1.7			
SDNT1608X471□3450◎TFTF	0.47	3450	1.4			
SDNT1608X681□3450◎TF	0.68	3450	1.2			
SDNT1608X102□3450◎TF	1.0	3450	1.0			
SDNT1608X152□3450◎TF	1.5	3450	0.81			
SDNT1608X222□3950◎TF	2.2	3950	0.67			
SDNT1608X302□3950◎TF	3.0	3950	0.55			
SDNT1608X332□3950◎TF	3.3	3950	0.55			
SDNT1608X472□3500◎TF	4.7	3500	0.44			
SDNT1608X472□3950◎TF	4.7	3950	0.46			
SDNT1608X502□3950◎TF	5.0	3950	0.44			
SDNT1608X682□3950◎TF	6.8	3950	0.38			
SDNT1608X103□3450◎TF	10	3450	0.31			
SDNT1608X103□3950◎TF	10	3950	0.33			
SDNT1608X153□3950◎TF	15	3950	0.25			
SDNT1608X223□4050◎TF	22	4050	0.21			
SDNT1608X333□4050◎TF	33	4050	0.17			
SDNT1608X473□4150◎TF	47	4150	0.14			
SDNT1608X503□4150◎TF	50	4150	0.13			
SDNT1608X683□4150◎TF	68	4150	0.12			
SDNT1608X104□4250◎TF	100	4250	0.10			
SDNT1608X154□4300◎TF	150	4300	0.08			
SDNT1608X224□4350◎TF	220	4350	0.06			
SDNT1608X334□4400◎TF	330	4400	0.05			
SDNT1608X474□4500◎TF	470	4500	0.04			
SDNT1608X684□4500◎TF	680	4500	0.03			
SDNT1608X135□4700◎TF	1300	4700	0.02			

VI. SDNT2012 Series

Part Number	Resistance at 25°C R25 (kΩ)	B constant (25-50°C) (K)	Max. Permissive Operating Current (25°C) (mA)	Thermal Time Constant	Dissipation Factor (mW/°C)	Rated Electric Power (mW)
SDNT2012X101□3380◎TF	0.10	3380	4.0	<5sec	2.0	200
SDNT2012X151□3380◎TF	0.15	3380	3.5			
SDNT2012X221□3450◎TF	0.22	3450	3.0			
SDNT2012X331□3450◎TF	0.33	3450	2.5			
SDNT2012X471□3450◎TF	0.47	3450	2.0			
SDNT2012X681□3450◎TF	0.68	3450	1.7			
SDNT2012X102□3450◎TF	1.0	3450	1.4			

Part Number	Resistance at 25°C R25 (kΩ)	B constant (25-50°C) (K)	Max. Permissible Operating Current (25°C) (mA)	Thermal Time Constant	Dissipation Factor (mW/°C)	Rated Electric Power (mW)
SDNT2012X152□3950◎TF	1.5	3950	1.2	<5sec	2.0	200
SDNT2012X202□3950◎TF	2.0	3950	1.0			
SDNT2012X222□3950◎TF	2.2	3950	0.90			
SDNT2012X332□3950◎TF	3.3	3950	0.72			
SDNT2012X472□3950◎TF	4.7	3950	0.65			
SDNT2012X502□3950◎TF	5.0	3950	0.60			
SDNT2012X682□3950◎TF	6.8	3950	0.50			
SDNT2012X103□3450◎TF	10	3450	0.40			
SDNT2012X103□3950◎TF	10	3950	0.44			
SDNT2012X153□3500◎TF	15	3500	0.32			
SDNT2012X223□4050◎TF	22	4050	0.31			
SDNT2012X333□4050◎TF	33	4050	0.24			
SDNT2012X473□4150◎TF	47	4150	0.20			
SDNT2012X503□4150◎TF	50	4150	0.18			
SDNT2012X683□4150◎TF	68	4150	0.16			
SDNT2012X104□4250◎TF	100	4250	0.14			
SDNT2012X154□4300◎TF	150	4300	0.11			
SDNT2012X224□4350◎TF	220	4350	0.08			
SDNT2012X334□4400◎TF	330	4400	0.06			
SDNT2012X474□4500◎TF	470	4500	0.05			
SDNT2012X684□4500◎TF	680	4500	0.04			
SDNT2012X135□4700◎TF	1300	4700	0.03			

※ □: Please specify the tolerance code of R25 (F=±1%, H=±3%, J=±5%, K=±10%).

※ ◎: Please specify the tolerance code of B value (F=±1%, H=±3%).

TYPICAL ELECTRICAL CHARACTERISTICS

