



N 沟道增强型场效应晶体管

N-CHANNEL MOSFET

FHP8N60W/FHF8N60W

主要参数 MAIN CHARACTERISTICS

ID	8A
VDSS	600V
Rdson-typ (@Vgs=10V)	0.9Ω
Qg-typ	26nC

用途 APPLICATIONS

高频开关电源	High efficiency switch mode power supplies
--------	--------------------------------------------

产品特性 FEATURES

低栅极电荷	Low gate charge
低 Crss (典型值 2.6pF)	Low Crss (typical 2.6pF)
开关速度快	Fast switching
100%经过雪崩测试	100% avalanche tested
100%经过热阻测试	100% DVDS tested
100%经过 RG 测试	100% Rg tested
高抗 dv/dt 能力	Improved dv/dt capability
RoHS 产品	RoHS product

封装形式 Package

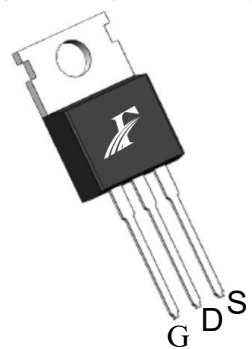

TO-220
FHP series



TO-220F
FHF series

等效电路 Equivalent Circuit

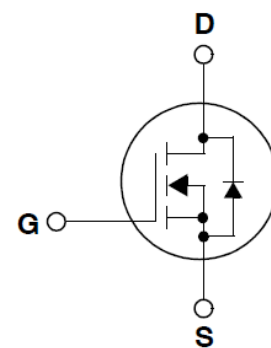

绝对最大额定值 ABSOLUTE RATINGS (Tc=25°C)

项目 Parameter	符号 Symbol	数值 Value		单位 Unit
		FHP8N60W	FHF8N60W	
最高漏极-源极直流电压 Drain-Source Voltage	V _{DS}	600		V
连续漏极电流* Drain Current -continuous *	I _D (T _C =25°C)	8		A
	I _D (T _C =100°C)	5.1		A
最大脉冲漏极电流 (注 1) Drain Current - pulse (note 1)	I _{DM}	32		A
最高栅源电压 Gate-Source Voltage	V _{GS}	±30		V
单脉冲雪崩能量 (注 2) Single Pulsed Avalanche Energy (note 2)	E _{AS}	180		mJ
雪崩电流 (注 1) Avalanche Current (note 1)	I _{AR}	6		A
重复雪崩能量 (注 1) Repetitive Avalanche Current (note 1)	E _{AR}	4		mJ
二极管反向恢复最大电压变化速率 (注 3) Peak Diode Recovery dv/dt (note 3)	dv/dt	5.0		V/ns
耗散功率 Power Dissipation	P _D (T _C =25°C)	198	50	W
	-Derate above 25°C	1.6	0.4	W/°C
最高结温及存储温度 Operating and Storage Temperature Range	T _J , T _{STG}	150, -55 to 150		°C
引线最高焊接温度 Maximum Lead Temperature for Soldering Purposes	T _L	300		°C

*漏极电流由最高结温限制

*Drain current limited by maximum junction temperature

电特性 ELECTRICAL CHARACTERISTICS

项目 Parameter	符号 Symbol	测试条件 Tests conditions	最小 Min	典型 Typ	最大 Max	单位 Units
关态特性 Off –Characteristics						
漏-源击穿电压 Drain-Source Voltage	BV _{DSS}	I _D =250μA, V _{GS} =0V	600	-	-	V
击穿电压温度特性 Breakdown Voltage Temperature Coefficient	ΔBV _{DSS} /ΔT _J	I _D =250μA, referenced to 25°C	-	0.6	-	V/°C
零栅压下漏极漏电流 Zero Gate Voltage Drain Current	I _{DSS}	V _{DS} =600V, V _{GS} =0V, T _C =25°C	-	-	10	μA
		V _{DS} =480V, T _C =125°C	-	-	100	μA
栅极体漏电流 Gate-body leakage current	I _{GSS} (F/R)	V _{DS} =0V, V _{GS} =±30V	-	-	±100	nA
通态特性 On-Characteristics						
阈值电压 Gate Threshold Voltage	V _{GS(th)}	V _{DS} = V _{GS} , I _D =250μA	2.0	-	4.0	V
静态导通电阻 Static Drain-Source On-Resistance	R _{DS(ON)}	V _{GS} =10V , I _D =4A	-	0.9	1.15	Ω
正向跨导 Forward Transconductance	g _{fs}	V _{DS} = 20V, I _D =4A (note 4)	-	12	-	S
动态特性 Dynamic Characteristics						
栅电阻 Gate Resistance	R _g	f=1.0MHz, V _{DS} OPEN	-	1.7	-	Ω
输入电容 Input capacitance	C _{iss}	V _{DS} =25V, V _{GS} =0V, f=1.0MHz	-	1230	-	pF
输出电容 Output capacitance	C _{oss}		-	90	-	
反向传输电容 Reverse transfer capacitance	C _{rss}		-	2.6	-	
开关特性 Switching Characteristics						
延迟时间 Turn-On delay time	t _{d(on)}	V _{DS} =300V, I _D =8A, R _G =5Ω V _{GS} =10V (note 4, 5)	-	33	-	ns
上升时间 Turn-On rise time	t _r		-	31	-	ns
延迟时间 Turn-Off delay time	t _{d(off)}		-	81	-	ns
下降时间 Turn-Off Fall time	t _f		-	36	-	ns
栅极电荷总量 Total Gate Charge	Q _g	V _{DS} =480V , I _D =8A , V _{GS} =10V (note 4, 5)	-	26	-	nC
栅-源电荷 Gate-Source charge	Q _{gs}		-	8	-	nC
栅-漏电荷 Gate-Drain charge	Q _{gd}		-	15	-	nC
漏-源二极管特性及最大额定值 Drain-Source Diode Characteristics and Maximum Ratings						
正向最大连续电流 Maximum Continuous Drain-Source Diode Forward Current		I _S	-	-	8	A
正向最大脉冲电流 Maximum Pulsed Drain-Source Diode Forward Current		I _{SM}	-	-	32	A
正向压降 Drain-Source Diode Forward Voltage	V _{SD}	V _{GS} =0V, I _S =8A	-	-	1.2	V
反向恢复时间 Reverse recovery time	t _{rr}	V _{GS} =0V, I _S =8A ,dI _F /dt=100A/μs (note 4)	-	327	-	ns
反向恢复电荷 Reverse recovery charge	Q _{rr}		-	1837	-	nC

热特性 THERMAL CHARACTERISTIC

项目 Parameter	符号 Symbol	FHP8N60W	FHF8N60W	单位 Unit
结到管壳的热阻 Thermal Resistance, Junction to Case	Rth(j-c)	0.63	2.5	°C/W
结到环境的热阻 Thermal Resistance, Junction to Ambient	Rth(j-A)	62.5	62.5	°C/W

注释:

- 1: 脉冲宽度由最高结温限制
- 2: L=10mH, IAS=6A, VDS=50V, RG=25 Ω, 起始结温 TJ=25°C
- 3: ISD ≤8A, di/dt ≤100A/μs, VDD≤BV_{DSS}, 起始结温 TJ=25°C
- 4: 脉冲测试: 脉冲宽度 ≤300μs, 占空比≤2%
- 5: 基本与工作温度无关

Notes:

- 1: Pulse width limited by maximum junction temperature
- 2: L=10mH, IAS=6A, VDS=50V, RG=25 Ω, Start TJ=25°C;
- 3: ISD ≤8A, di/dt ≤100A/μs, VDD≤BV_{DSS}, Starting TJ=25°C
- 4: Pulse Test: Pulse Width ≤300μs, Duty Cycle≤2%
- 5: Essentially independent of operating temperature

特性曲线

(ELECTRICAL CHARACTERISTICS (curves))

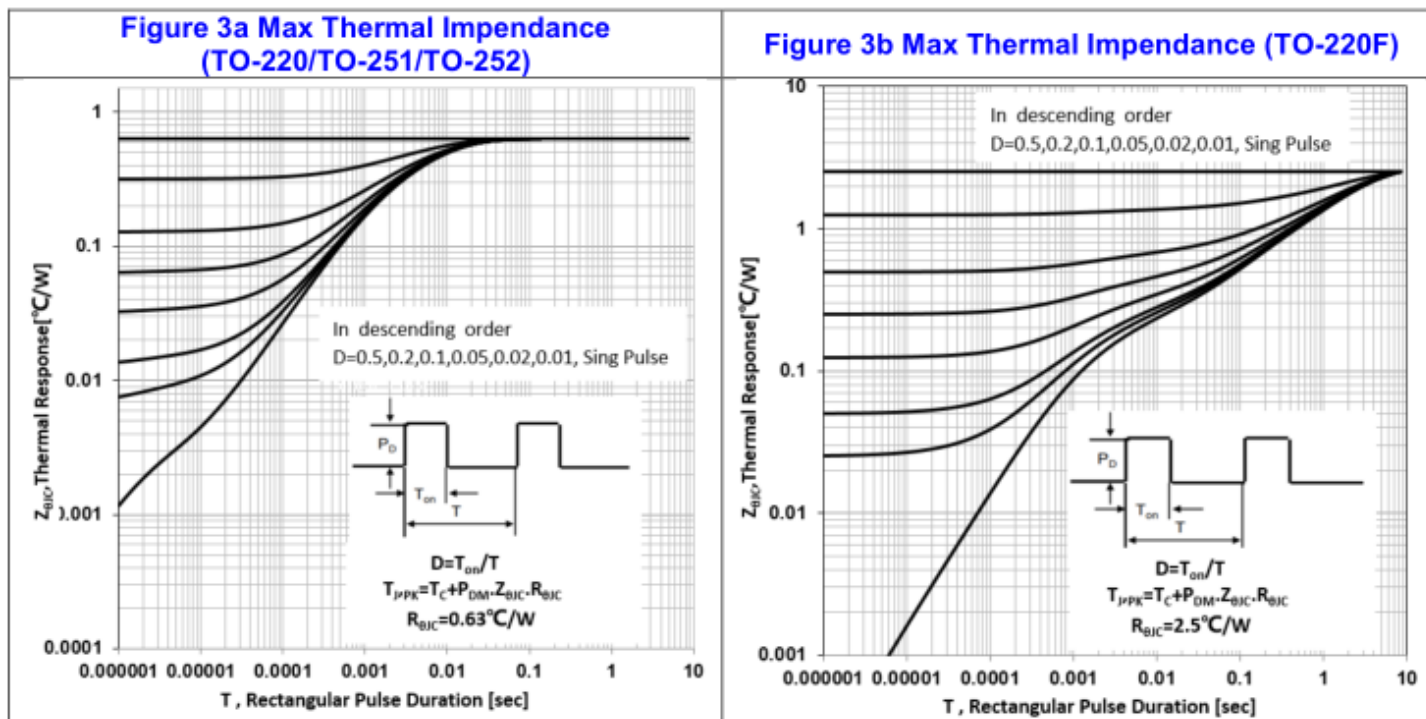
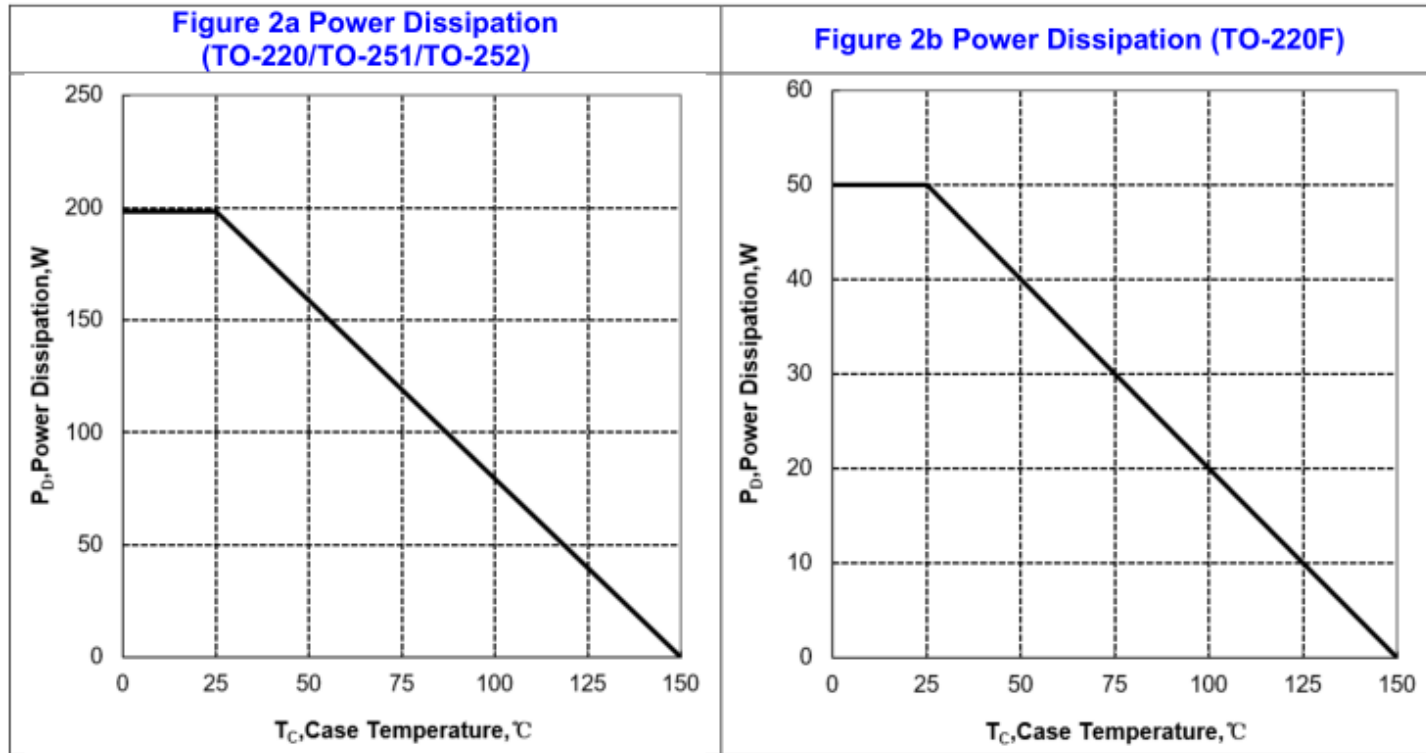
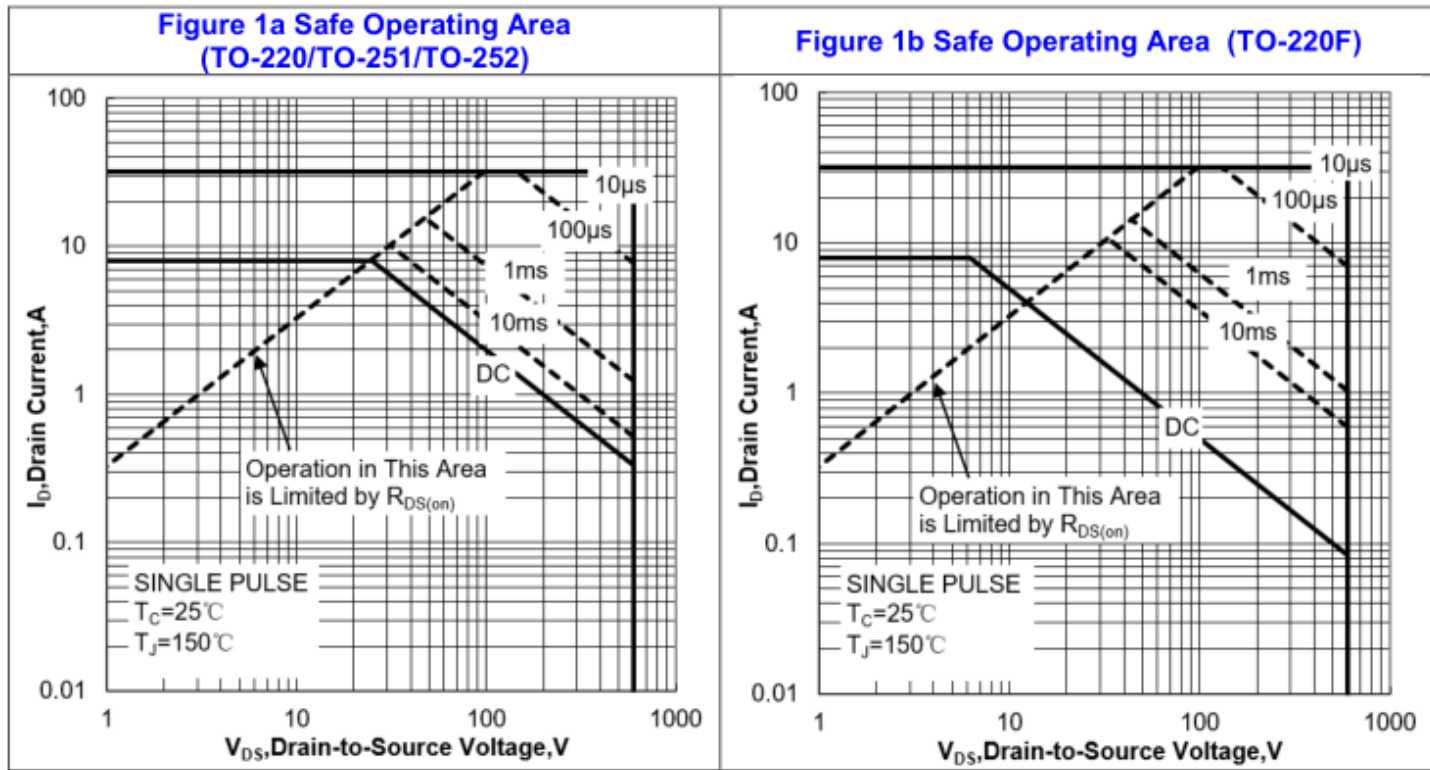

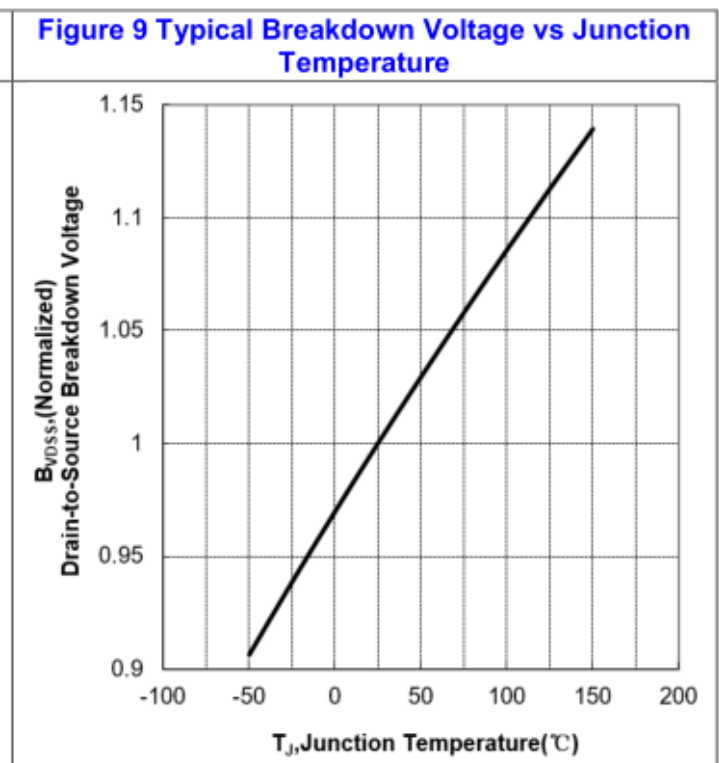
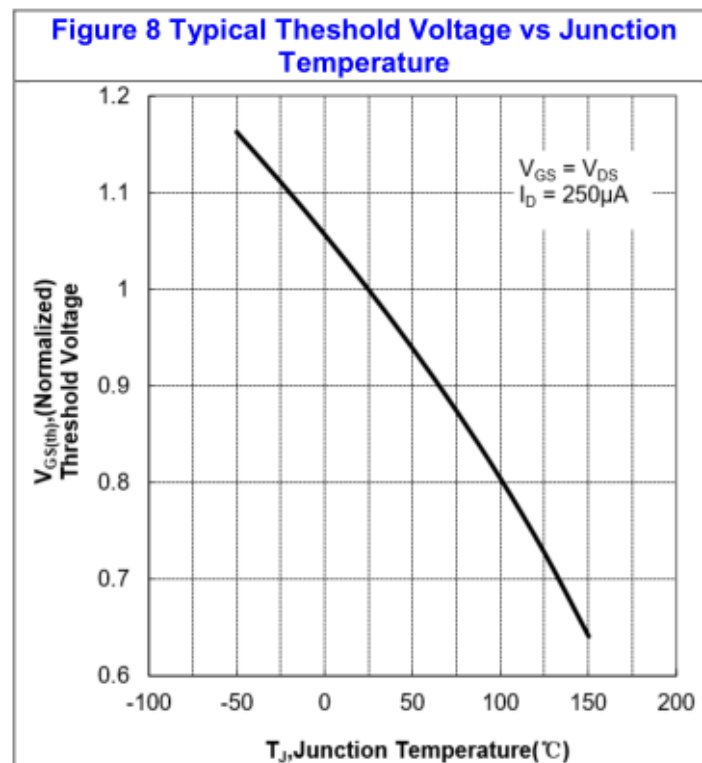
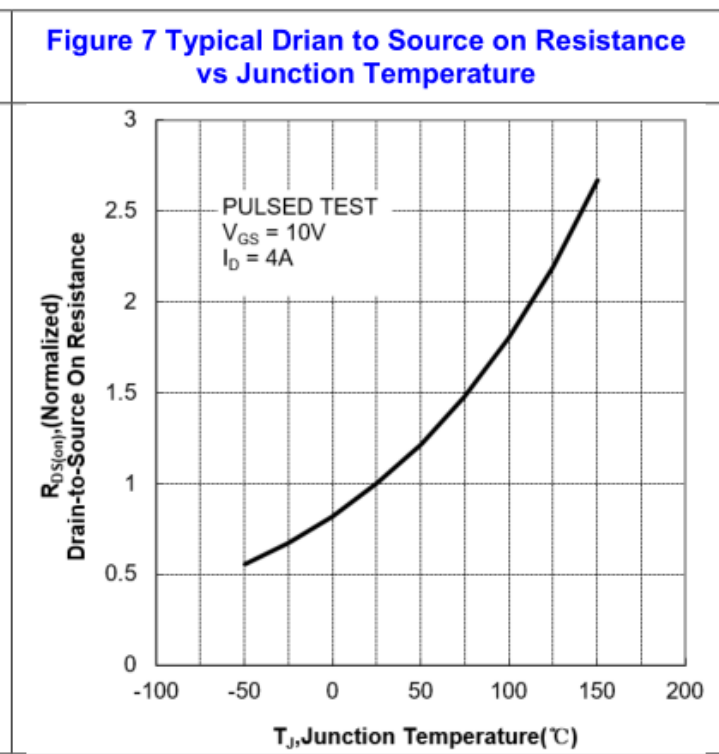
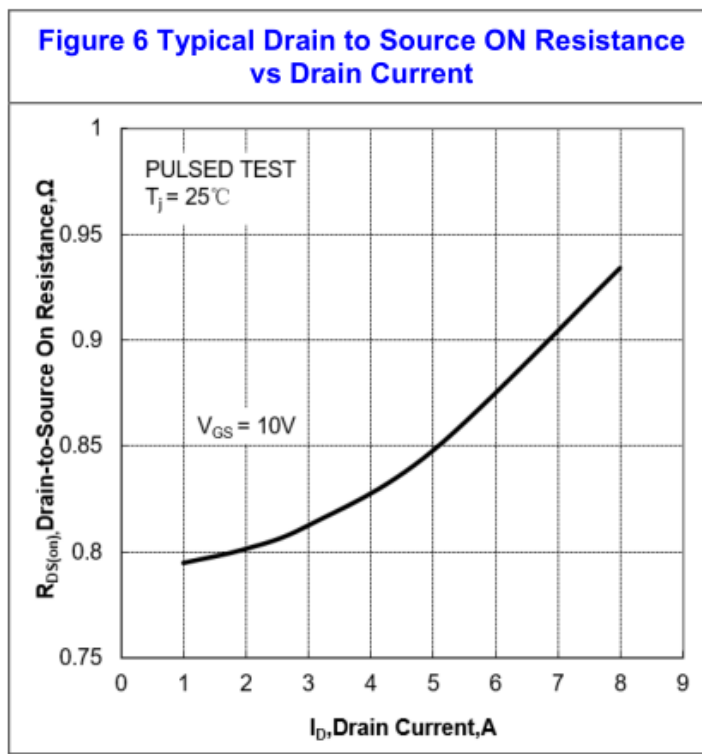
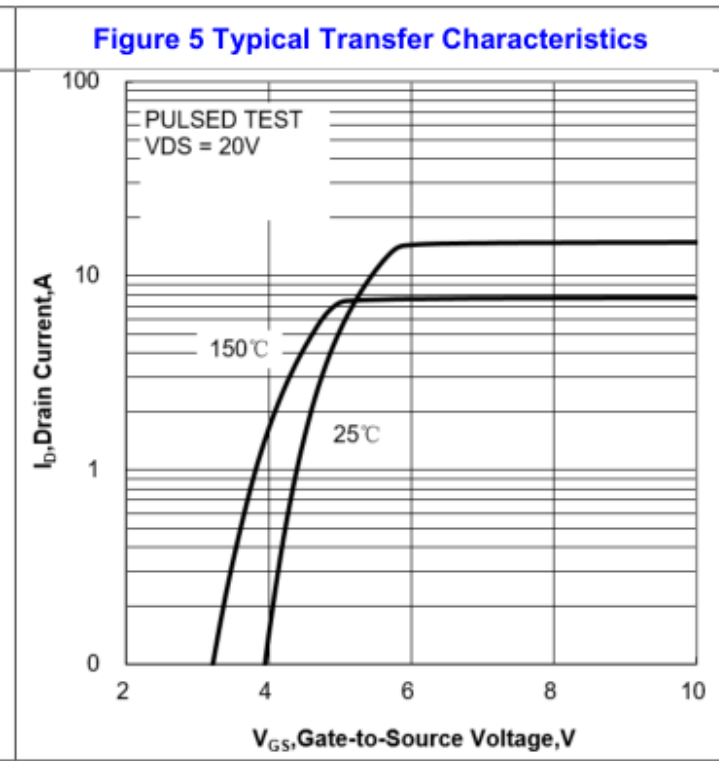
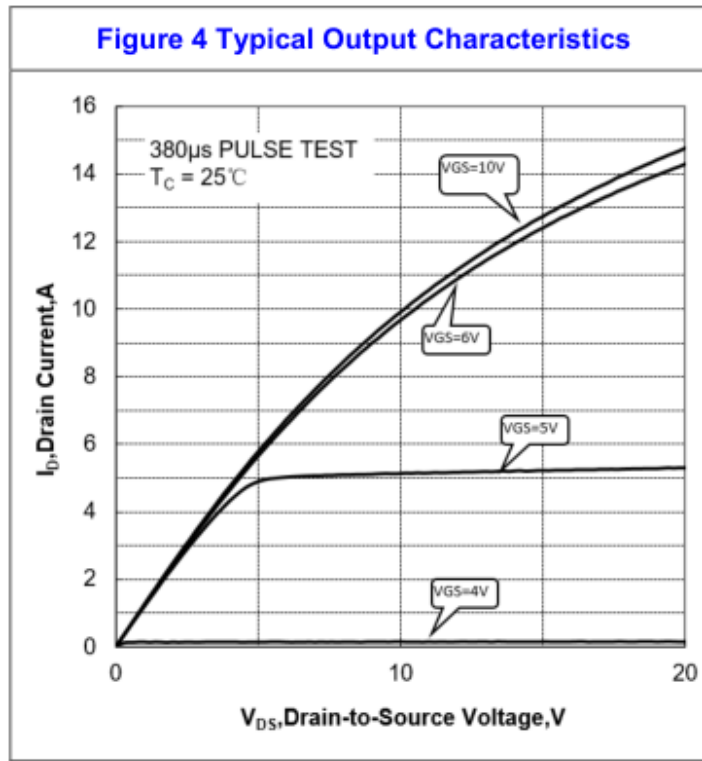

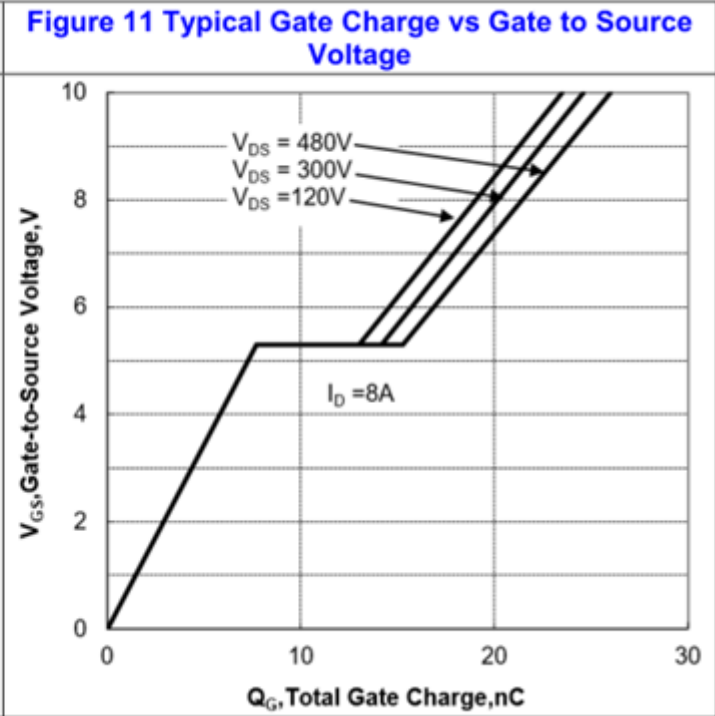
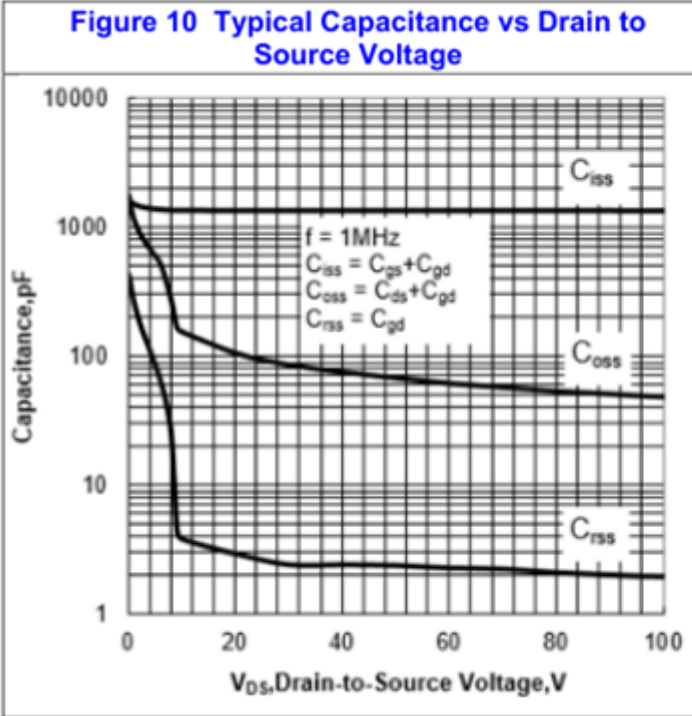

Test Circuit and Waveform

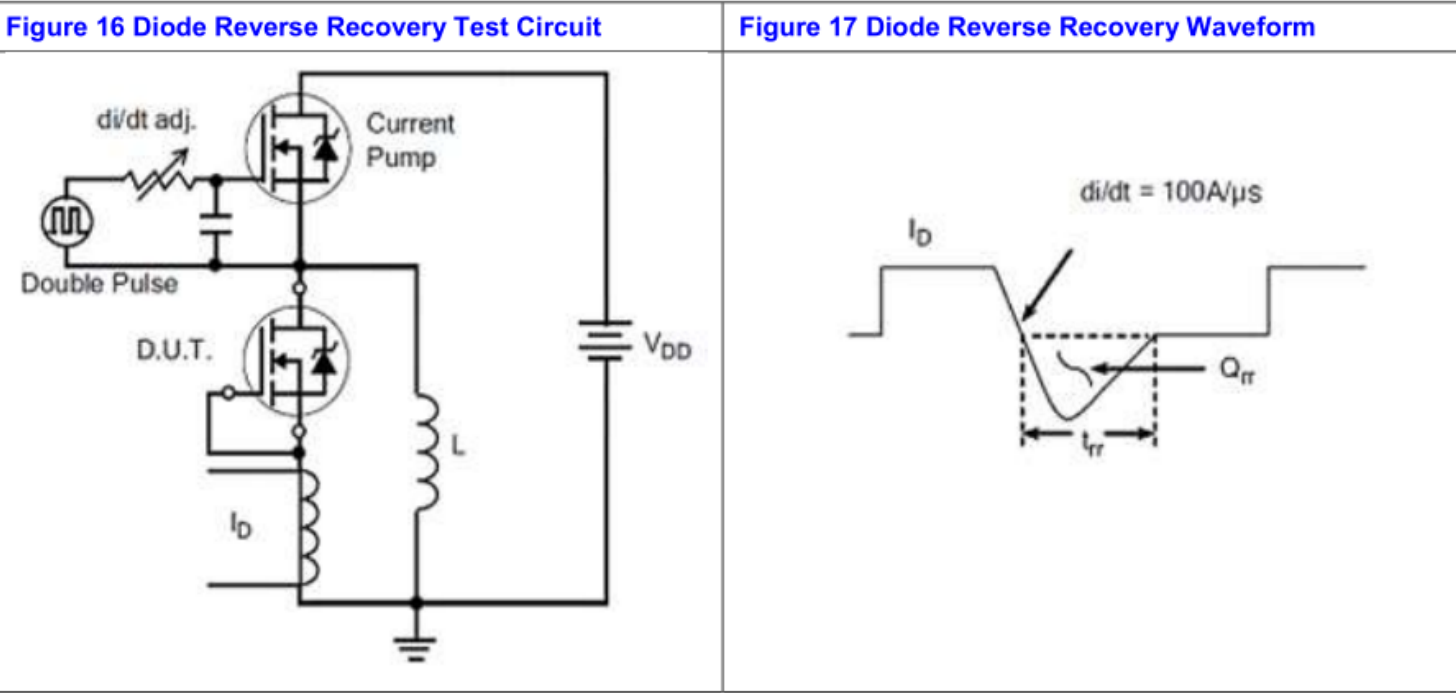
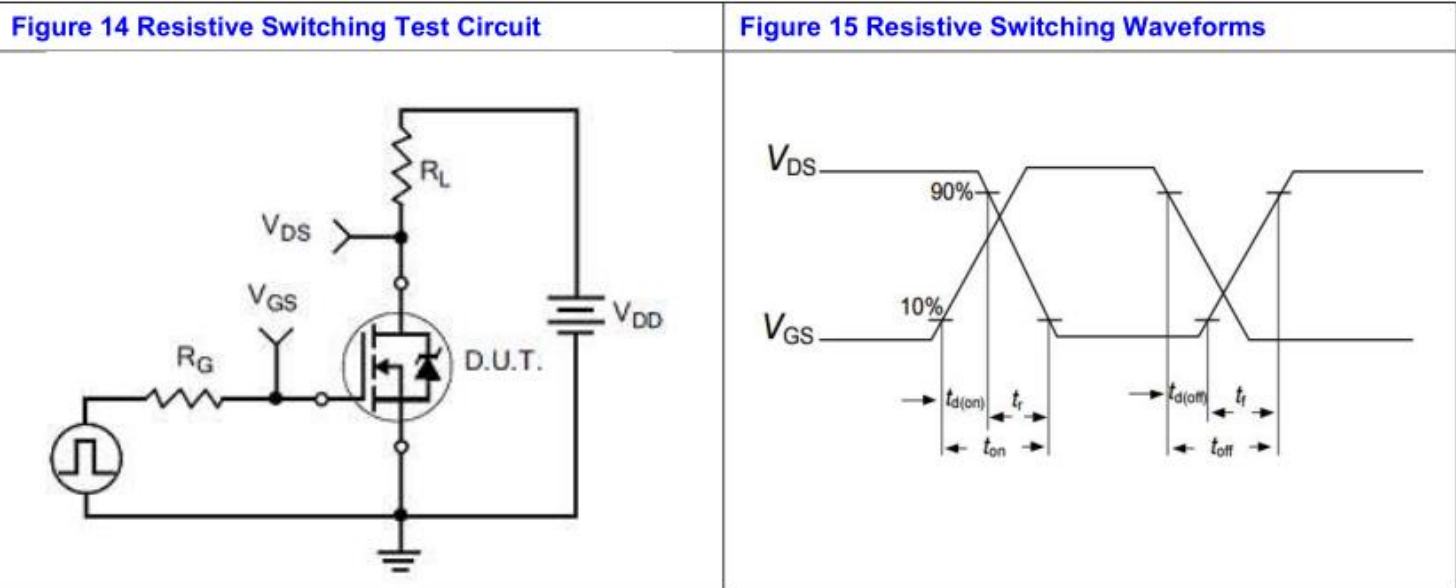
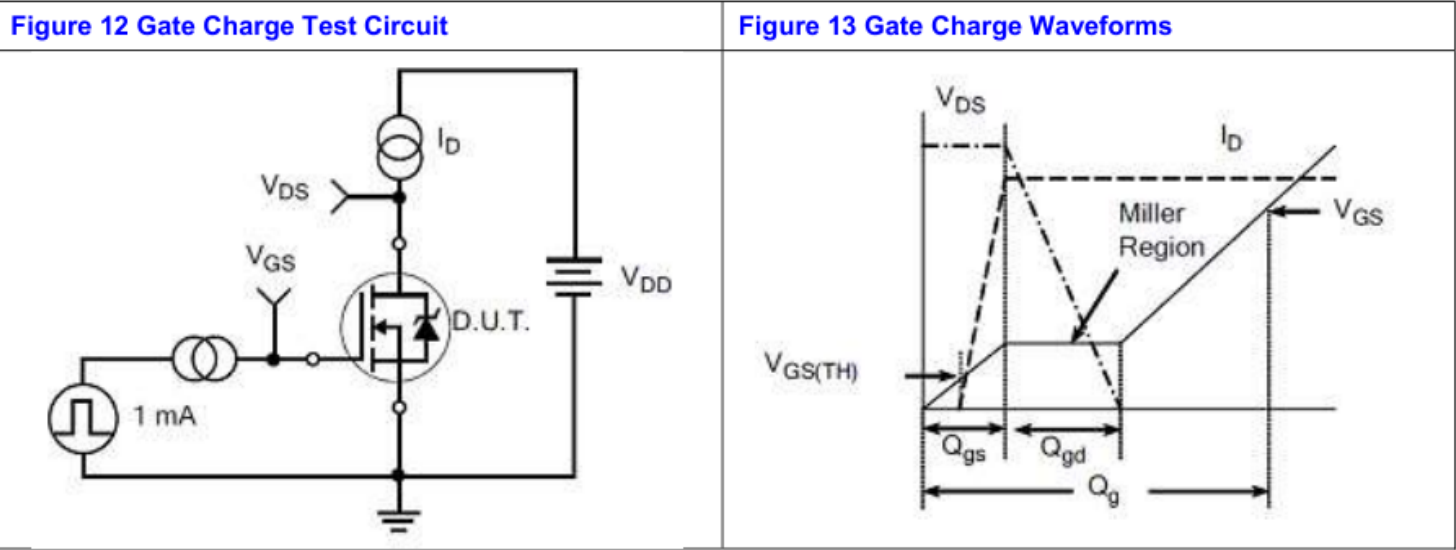

Figure 18 Unclamped Inductive Switching Test Circuit

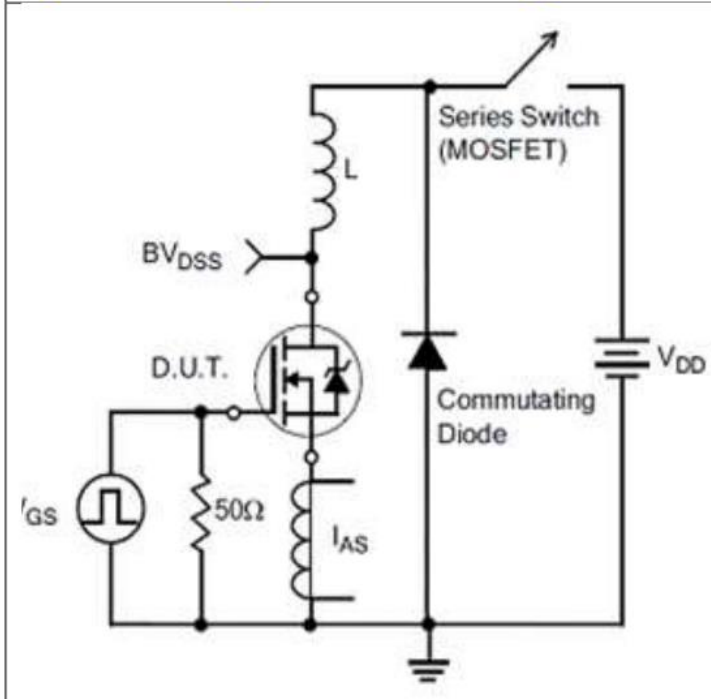
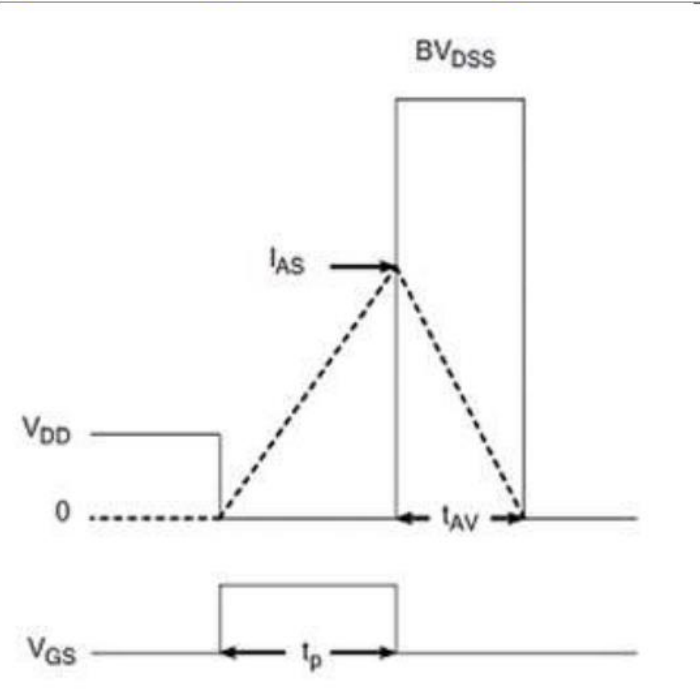
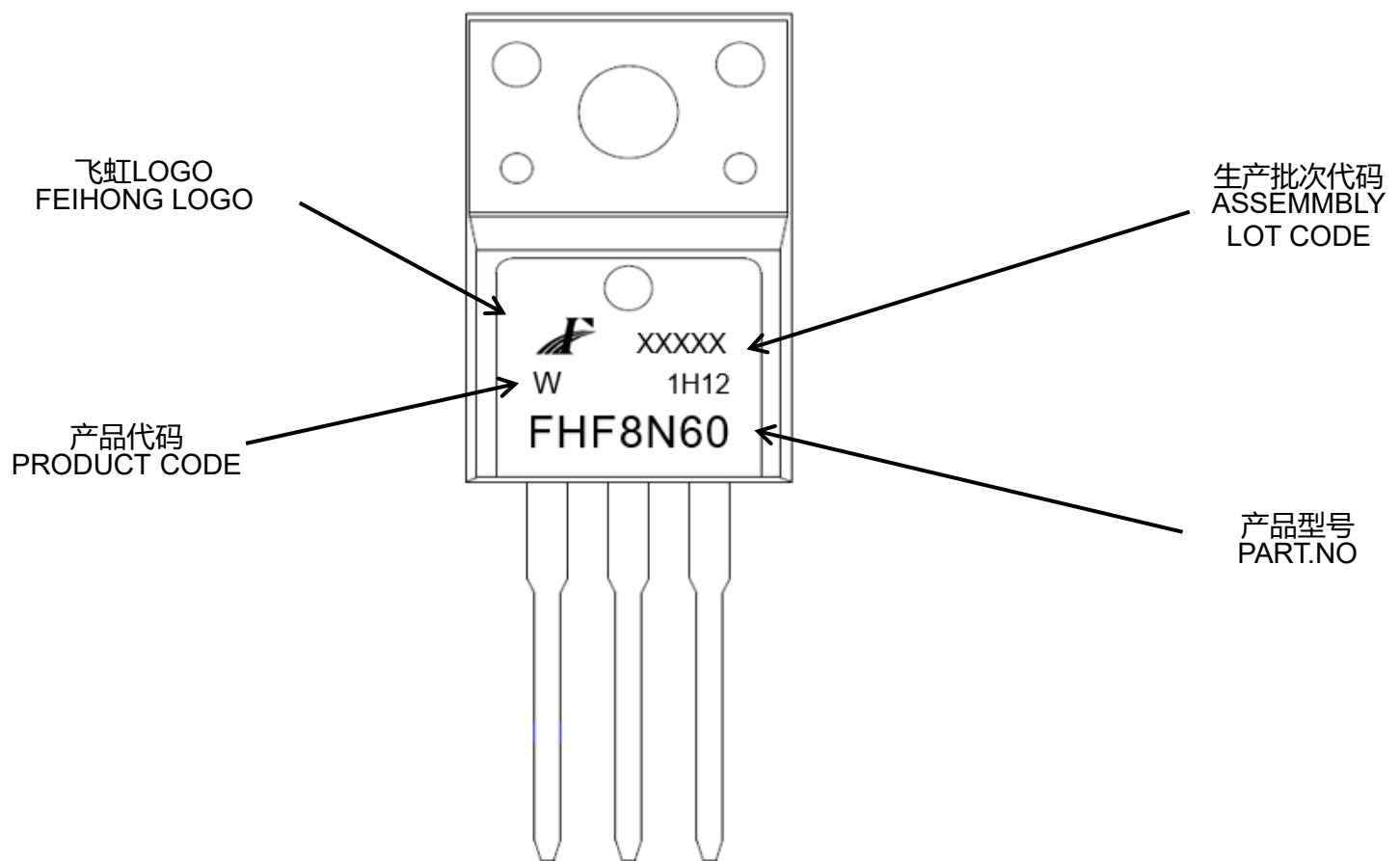
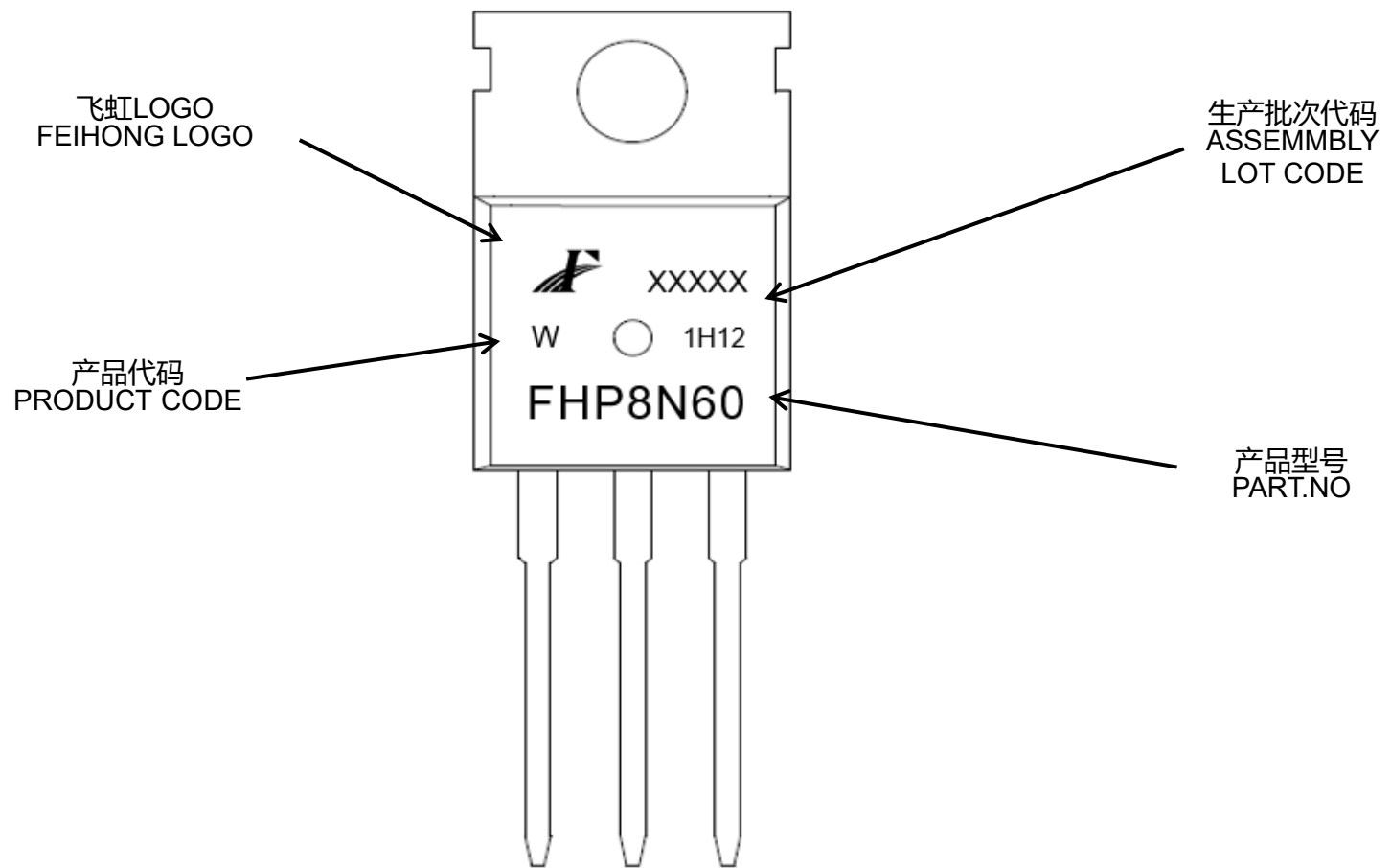

Figure 19 Unclamped Inductive Switching Waveform



印记 Marking:



外形尺寸:

Package Dimension:

TO-220

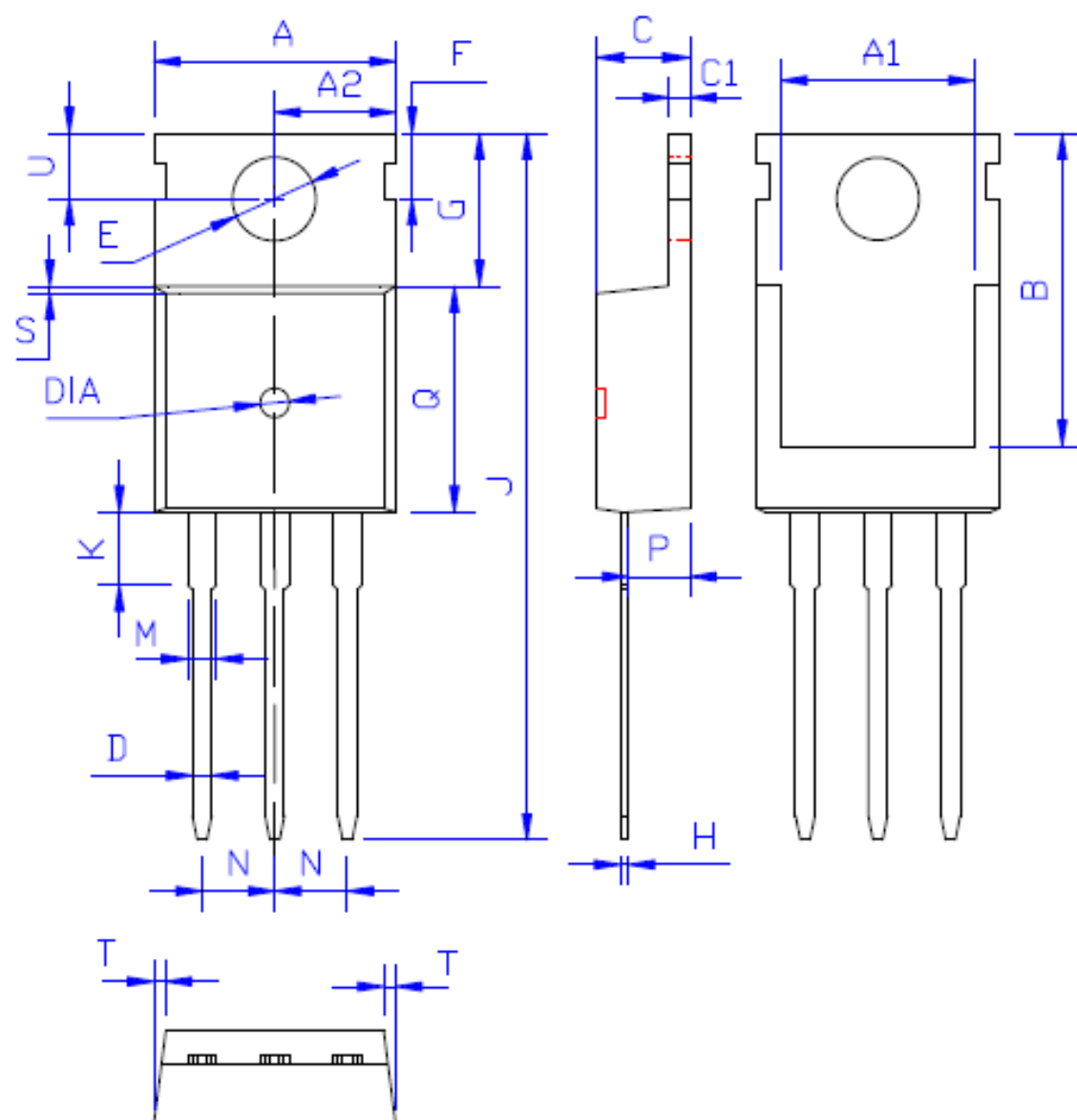

DIM	MILLIMETERS
A	10.00±0.30
A1	8.00±0.30
A2	5.00±0.30
B	13.20±0.40
C	4.50±0.20
C1	1.30±0.20
D	0.80±0.20
E	3.60±0.20
F	3.00±0.30
G	6.60±0.40
H	0.50±0.20
J	28.88±0.50
K	3.00±0.30
M	1.30±0.30
N	Typical 2.54
P	2.40±0.40
Q	9.20±0.40
S	0.25±0.15
T	0.25±0.15
U	2.80±0.30
DIA	宽 1.50±0.10 深 0.50 MAX

(Unit: mm)

外形尺寸:

Package Dimension:

TO-220F

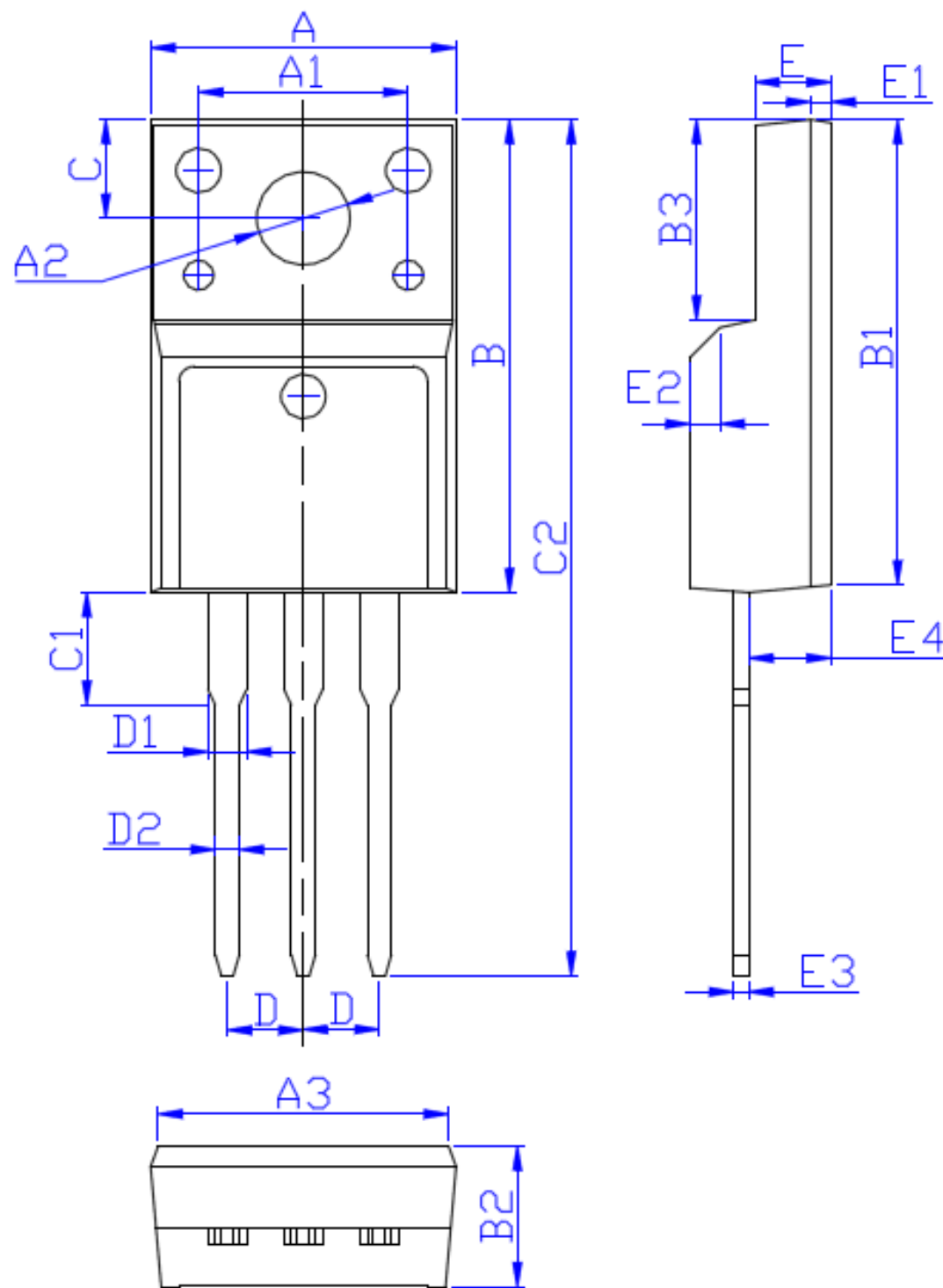

DIM	MILLIMETERS
A	10.16±0.30
A1	7.00±0.20
A2	3.12±0.20
A3	9.70±0.30
B	15.90±0.50
B1	15.60±0.50
B2	4.70±0.30
B3	6.70±0.30
C	3.30±0.25
C1	3.25±0.30
C2	28.70±0.50
D	Typical 2.54
D1	1.47 (MAX)
D2	0.80±0.20
E	2.55±0.25
E1	0.70±0.25
E2	1.0×45°
E3	0.50±0.20
E4	2.75±0.30

(Unit:mm)