

### 主要参数 MAIN CHARACTERISTICS

$I_c$ (100°C)	40 A
$V_{CES}$	650 V
$V_{cesat-typ}$ (@ $I_c=40A$ )	1.45 V

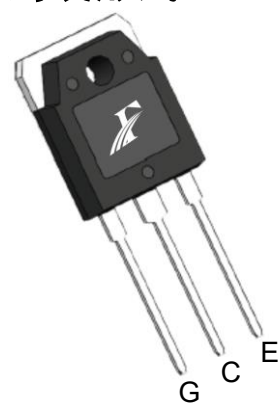
### 用途 APPLICATIONS

电机驱动	Motor drive
变频器	Variable-frequency drive
工业缝纫机	Industrial sewing machine

### 产品特性 FEATURES

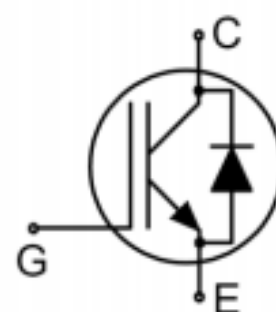
Trench-FS 技术	Trench Field Stop technology
低栅极电荷	Low gate charge
低开关损耗	Low Switching losses
低 $V_{CEsat}$	Low $V_{CEsat}$
符合 RoHS 标准	ROHS compliant
带有反向并行快恢复二极管	With anti-parallel fast recovery diode
正温度系数	Positive temperature coefficient
高可靠性	High reliability

### 封装形式 Package



TO-3PN  
FHA series

### 等效电路 Equivalent Circuit



### 绝对最大额定值 ABSOLUTE RATINGS ( $T_c=25^\circ C$ )

项目 parameter	符号 Symbol	数值 Value	单位 Unit
最高集电极-发射极直流电压 Collector-Emmitter Voltage	$V_{CE}$	650	V
连续集电极极电流 Collector Current-continuous	$I_c$	( $T_c=25^\circ C$ )	80
		( $T_c=100^\circ C$ )	40
最大脉冲集电极极电流 (注1) Collector Current – pulse (note 1)	$I_{CM}$	160	A
二极管连续正向电流 Diode Continuous Forward Current	$I_F$	( $T_c=25^\circ C$ )	40
		( $T_c=100^\circ C$ )	20
二极管最大正向电流 Diode Maximum Forward Current	$I_{FM}$	80	A
最高栅极发射极电压 Gate-Emmitter Voltage	$V_{GE}$	$\pm 30$	V
短路耐受时间 Short circuit withstand time $V_{GE}=15V$ , $V_{CC}\leq 400V$ , Allowed number of short circuits < 1000, Times between short circuits: $\geq 1.0s$ , $T_J \leq 175^\circ C$	$t_{sc}$	5.0	us
耗散功率 Power Dissipation ( $T_c=25^\circ C$ )	$P_D$	298	W
最高结温及存储温度 Operating and Storage Temperature Range	$T_J$ , $T_{STG}$	175, -55~+175	$^\circ C$
引线最高焊接温度 Maximum Lead Temperature for Soldering Purposes	TL	260	$^\circ C$

注1: 集极电流由最高结温限制

Note1: Collector current limited by maximum junction temperature

## 电特性 ELECTRICAL CHARACTERISTICS(at T<sub>C</sub>= 25°C, unless otherwise specified)

项目 Parameter	符号 Symbol	测试条件 Tests conditions	最小 Min	典型 Typ	最大 Max	单位 Units
<b>关态特性 Off –Characteristics</b>						
集电极-发射极击穿电压 Collector-Emmitter Voltage	BV <sub>CES</sub>	V <sub>GE</sub> =0V, I <sub>C</sub> =250uA	650	-	-	V
击穿电压温度特性 Breakdown Voltage Temperature Coefficient	ΔBV <sub>CES</sub> /ΔT <sub>J</sub>	I <sub>C</sub> =1mA, referenced to 25°C	-	0.65	-	V/°C
零栅压下集电极漏电流 Zero Gate Voltage Collector Current	I <sub>CES</sub>	V <sub>CE</sub> =650V, V <sub>GE</sub> =0V	-	-	600	nA
栅极体漏电流 Gate-Emmitter leakage current	I <sub>GES(F/R)</sub>	V <sub>CE</sub> =0V, V <sub>GE</sub> =±30V	-	-	±200	nA
<b>通态特性 On-Characteristics</b>						
阈值电压 Gate-Emmitter Threshold Voltage	V <sub>GE(th)</sub>	V <sub>CE</sub> = V <sub>GE</sub> , I <sub>C</sub> =1mA	4.9	5.2	6.5	V
饱和压降 Collector-Emmitter saturation Voltage	V <sub>CESAT</sub>	V <sub>GE</sub> =15V, I <sub>C</sub> =40A, T <sub>J</sub> =25°C T <sub>J</sub> =125°C T <sub>J</sub> =175°C	- - -	1.45 1.65 1.75	1.75 - -	V
<b>动态特性 Dynamic Characteristics</b>						
开启延迟时间 Turn-On delay time	td(on)	V <sub>GE</sub> =15V, V <sub>CC</sub> =400V, I <sub>C</sub> =40A, R <sub>G</sub> =5Ω, T <sub>J</sub> =25°C, Inductive Load	-	20	-	ns
上升时间 Turn-On rise time	tr		-	33	-	ns
关断延迟时间 Turn-Off delay time	td(off)		-	112	-	ns
下降时间 Turn-Off Fall time	tf		-	66	-	ns
开启损耗 Turn-on energy	Eon		-	0.65	-	mJ
关断损耗 Turn-off energy	Eoff		-	0.68	-	
总的开关损耗 Total switching energy	Ets		-	1.33	-	
开启延迟时间 Turn-On delay time	td(on)	V <sub>GE</sub> =15V, V <sub>CC</sub> =400V, I <sub>C</sub> =40A, R <sub>G</sub> =5Ω, T <sub>J</sub> =175°C, Inductive Load	-	19	-	ns
上升时间 Turn-On rise time	tr		-	34	-	ns
关断延迟时间 Turn-Off delay time	td(off)		-	148	-	ns
下降时间 Turn-Off Fall time	tf		-	112	-	ns
开启损耗 Turn-on energy	Eon		-	0.87	-	mJ
关断损耗 Turn-off energy	Eoff		-	0.89	-	
总的开关损耗 Total switching energy	Ets		-	1.76	-	
栅极电荷总量 Total Gate Charge	Qg	V <sub>CE</sub> =520V, I <sub>C</sub> =20A, V <sub>GE</sub> =15V	-	110	-	nC
栅极-发射极电荷 Gate-emitter charge	Qge		-	55	-	
栅极-集电极电荷 Gate-collector charge	Qgc		-	22	-	
集电极短路电流 Short circuit collector current (最大值100sc; 短路时间间隔: ≥1.0s)	I <sub>C(sc)</sub>	V <sub>GE</sub> =15V, V <sub>CC</sub> ≤400V, t <sub>sc</sub> ≤5us, T <sub>J</sub> ≤175°C		235		A
栅极电阻 Gate Resistance	Rg	f=1.0MHz, V <sub>CE</sub> OPEN	-	3.0	-	Ω
输入电容 Input capacitance	Cies	V <sub>CE</sub> =25V, V <sub>GE</sub> =0V, f=1.0MHz	-	2122	-	pF
输出电容 Output capacitance	Coes		-	124	-	
反向传输电容 Reverse transfer capacitance	Cres		-	23	-	

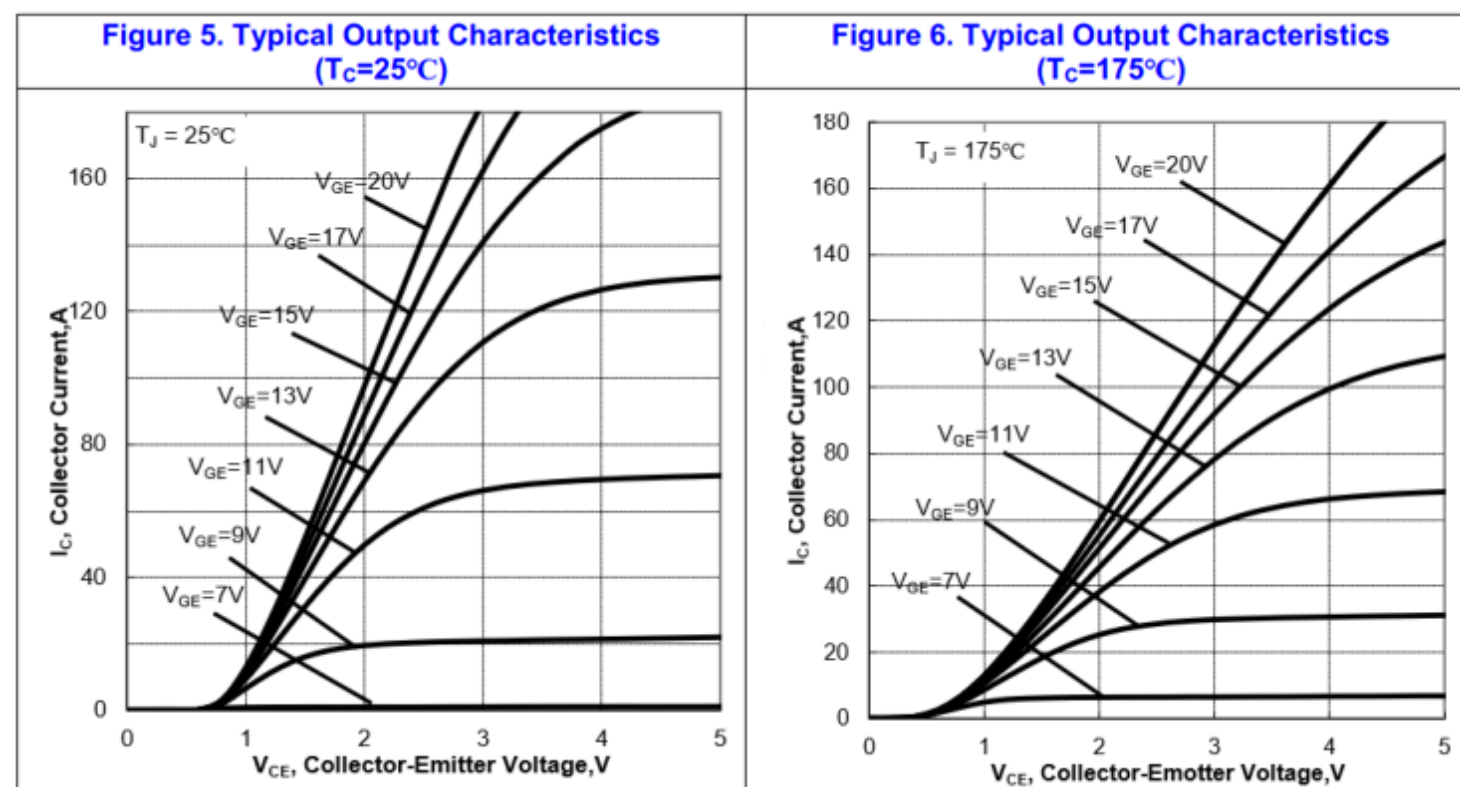
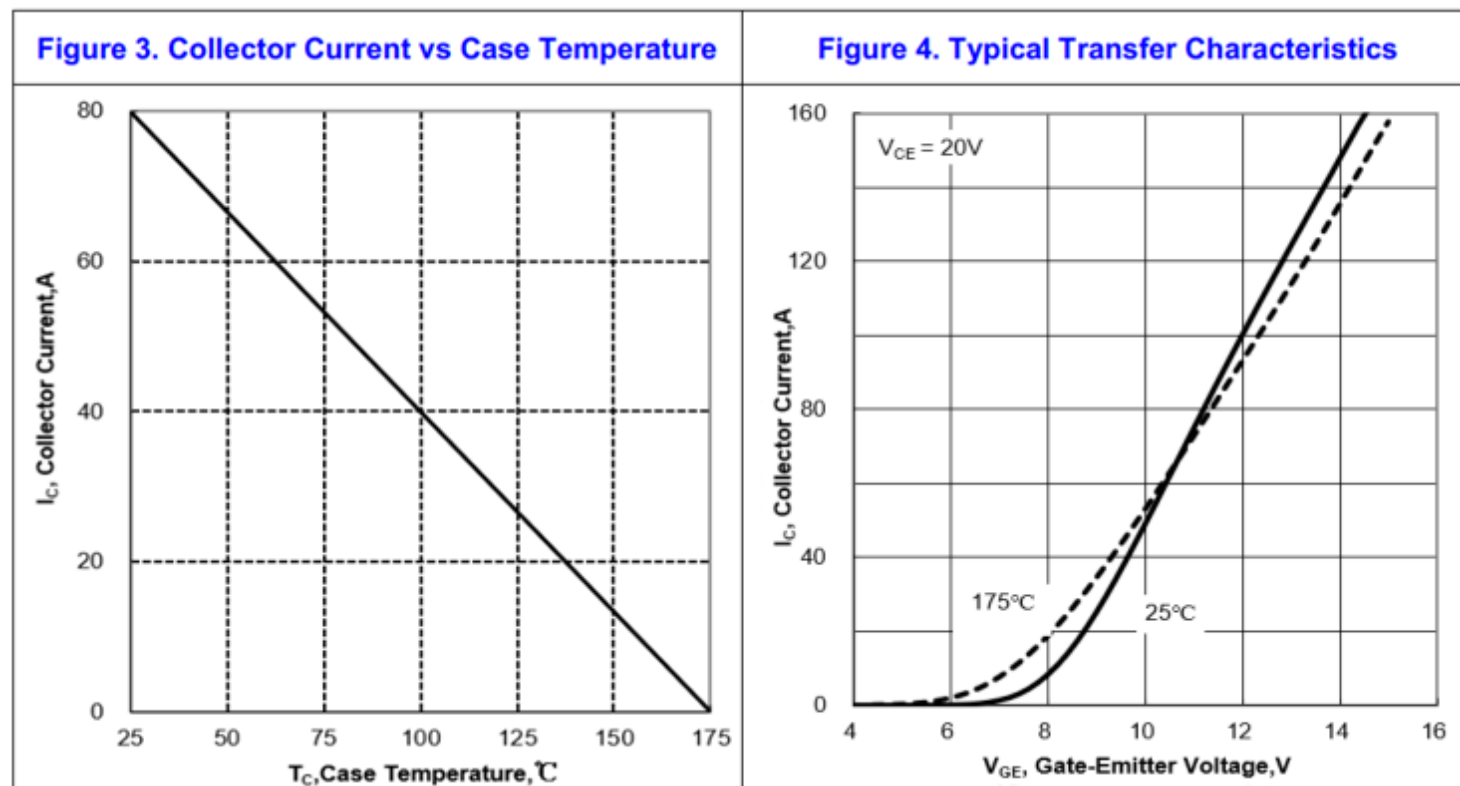
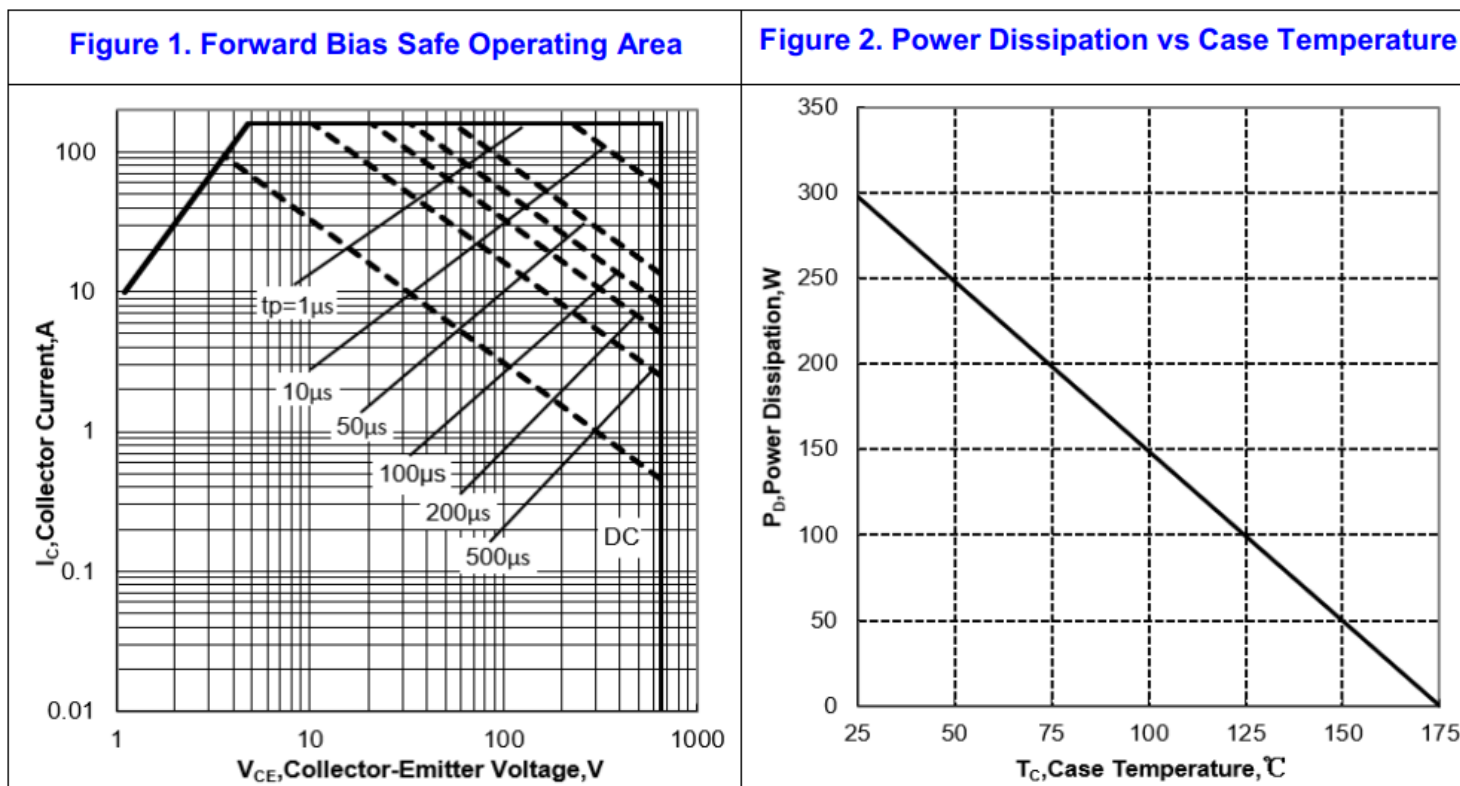
二极管特性 Diode characteristics						
项目 Parameter	符号 Symbol	测试条件 Tests conditions	最小 Min	典型 Typ	最大 Max	单位 Units
正向压降 Diode Forward Voltage	$V_{FM}$	$I_F=40A$	-	1.77	2.5	V
反向恢复时间 Reverse recovery time	trr	$I_F=20A,$ $dI/dt=200A/\mu s,$ $T_J=25^\circ C$	-	97	-	ns
反向恢复电流 Reverse recovery current	Irr		-	1.8	-	A
反向恢复电荷 Reverse recovery charge	Qrr		-	109	-	nC
反向恢复时间 Reverse recovery time	trr	$I_F=40A,$ $dI/dt=200A/\mu s,$ $T_J=25^\circ C$	-	127	-	ns
反向恢复电流 Reverse recovery current	Irr		-	4.8	-	A
反向恢复电荷 Reverse recovery charge	Qrr		-	326	-	nC
反向恢复时间 Reverse recovery time	trr	$I_F=20A,$ $dI/dt=200A/\mu s,$ $T_J=175^\circ C$	-	147	-	ns
反向恢复电流 Reverse recovery current	Irr		-	7.8	-	A
反向恢复电荷 Reverse recovery charge	Qrr		-	742	-	nC
反向恢复时间 Reverse recovery time	trr	$I_F=40A,$ $dI/dt=200A/\mu s,$ $T_J=175^\circ C$	-	158	-	ns
反向恢复电流 Reverse recovery current	Irr		-	9	-	A
反向恢复电荷 Reverse recovery charge	Qrr		-	870	-	nC

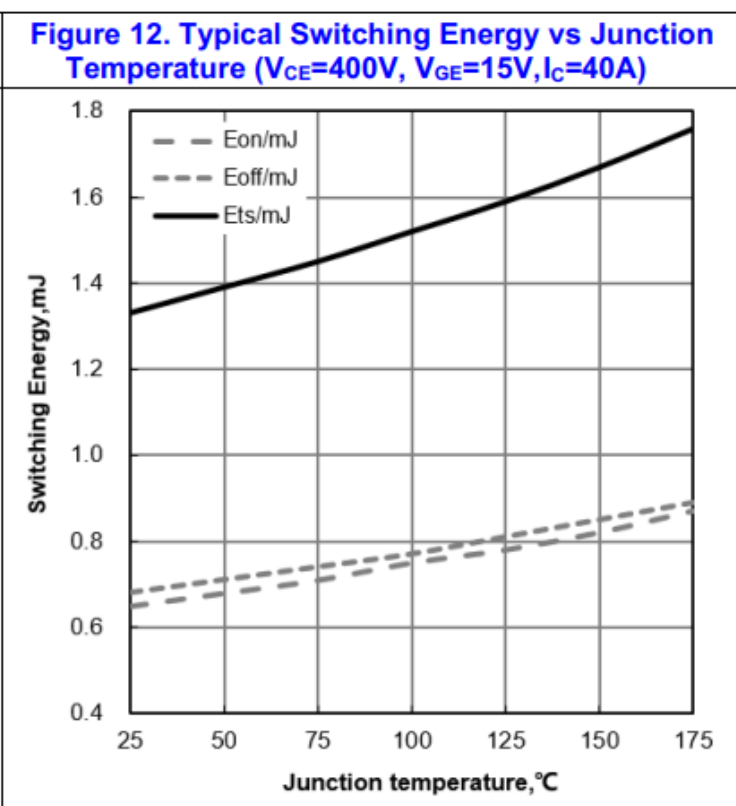
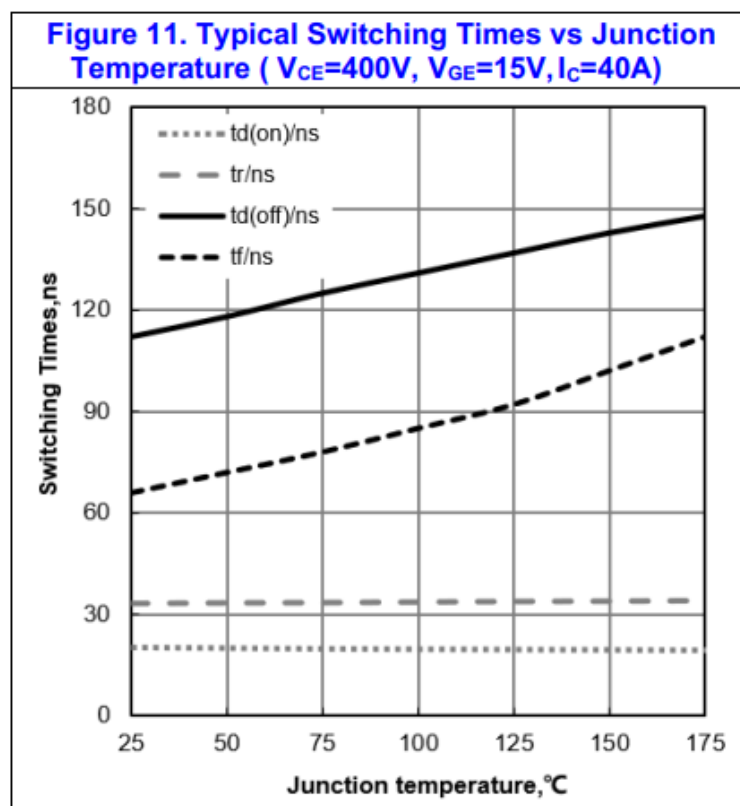
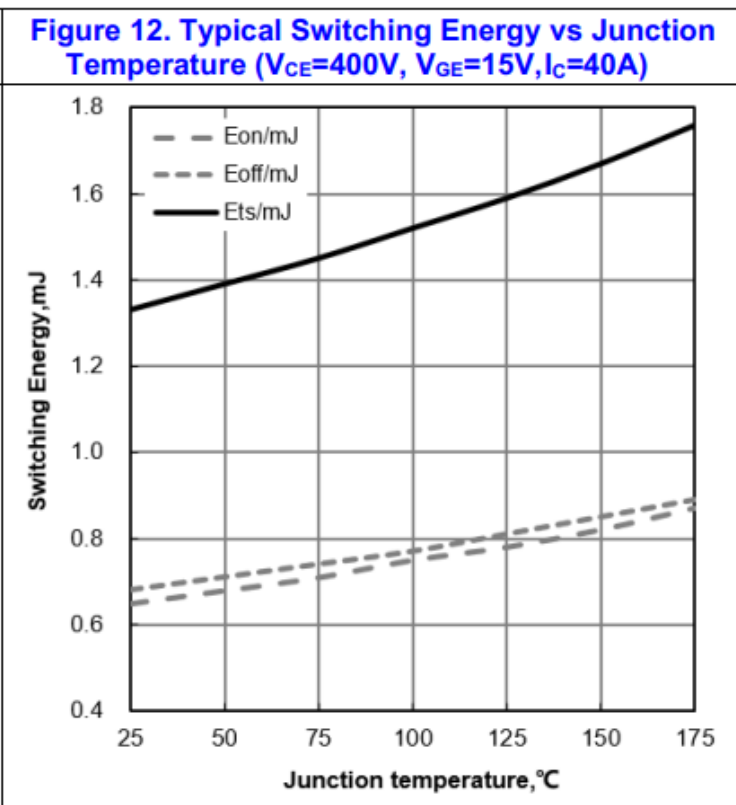
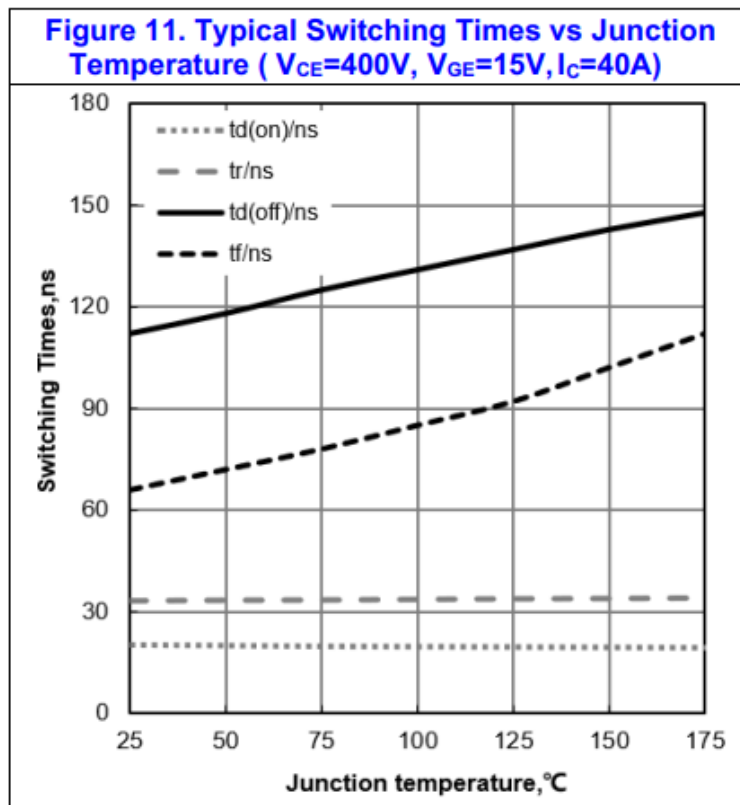
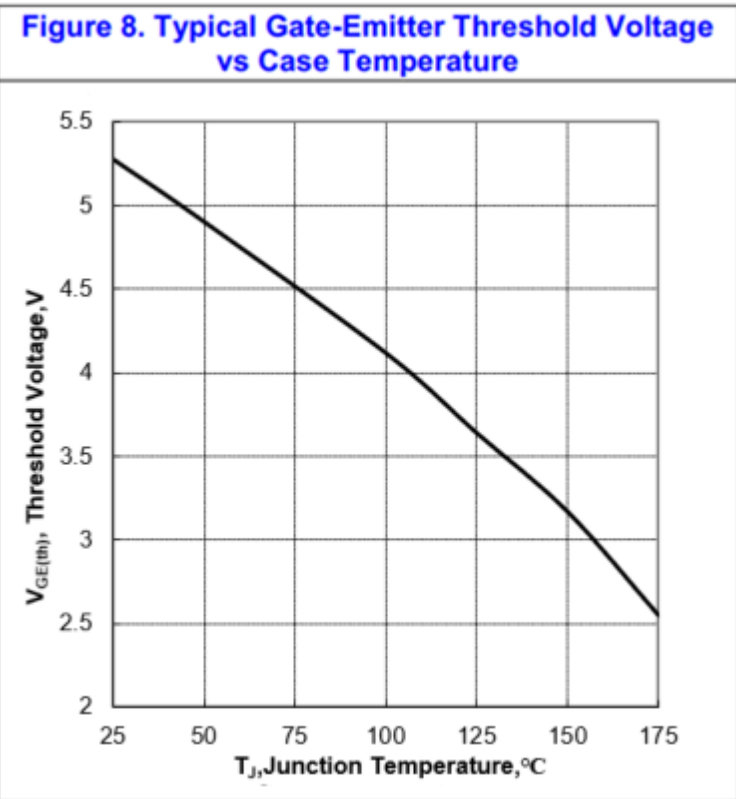
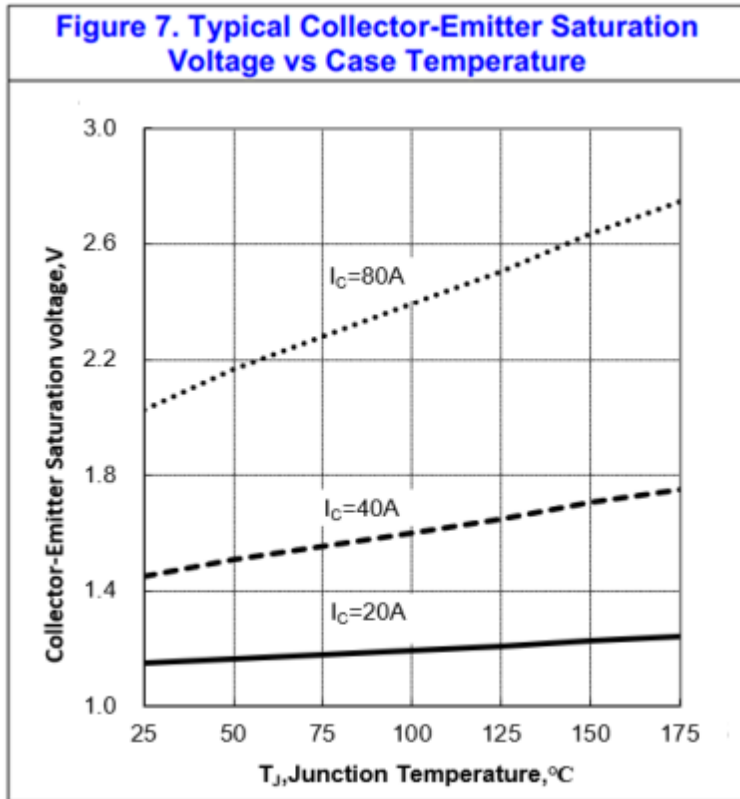
### 热特性 THERMAL CHARACTERISTIC

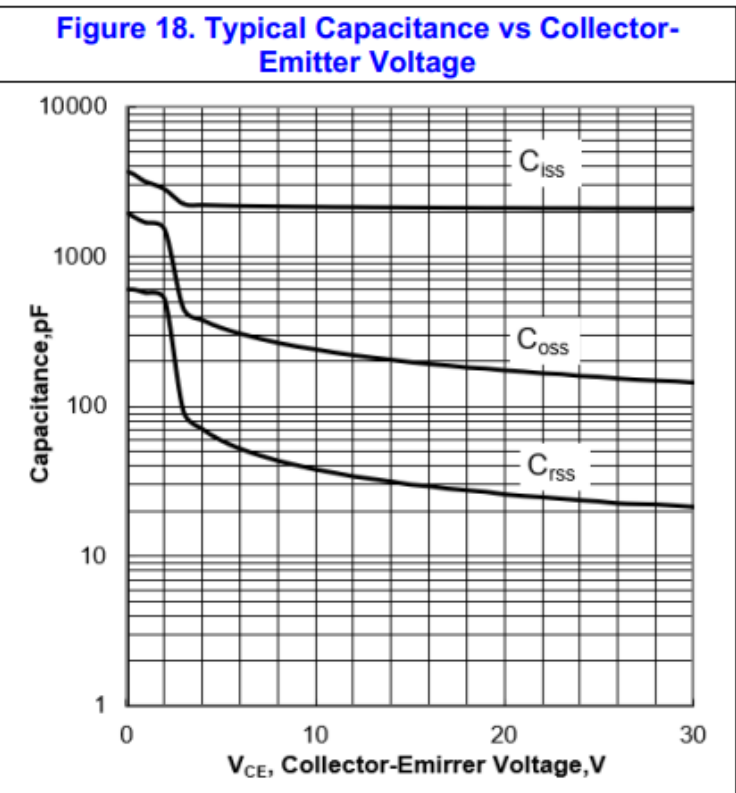
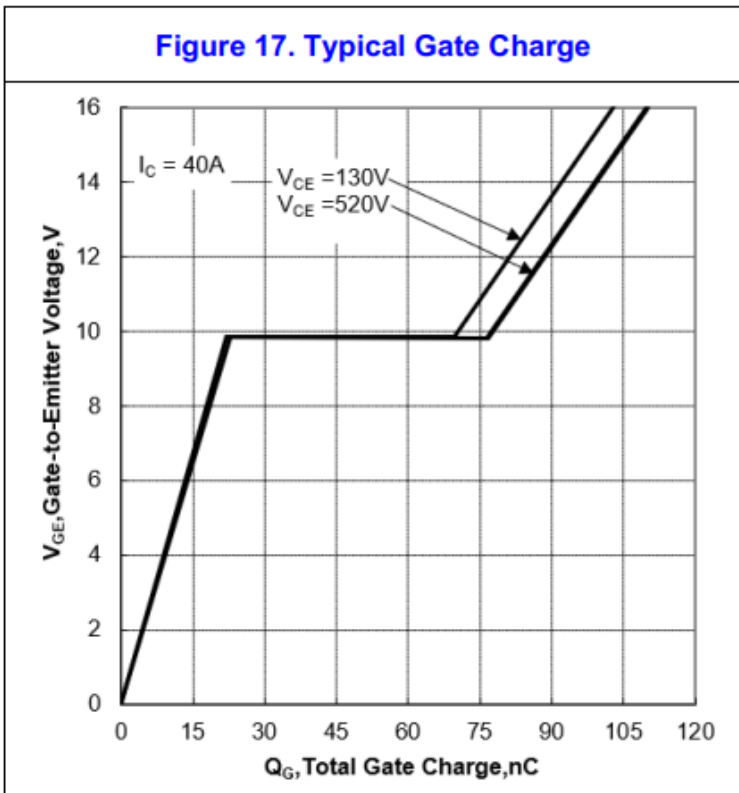
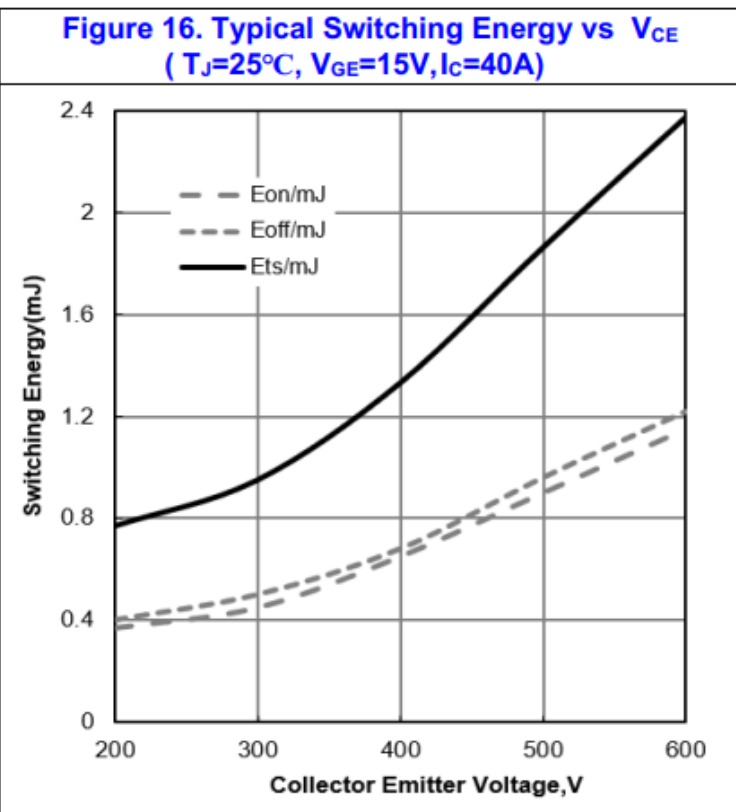
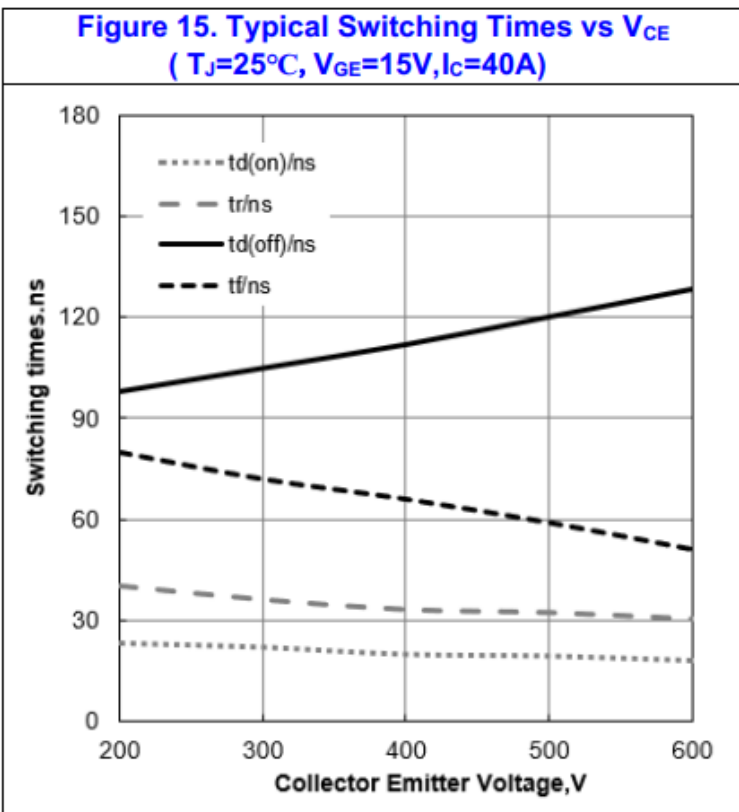
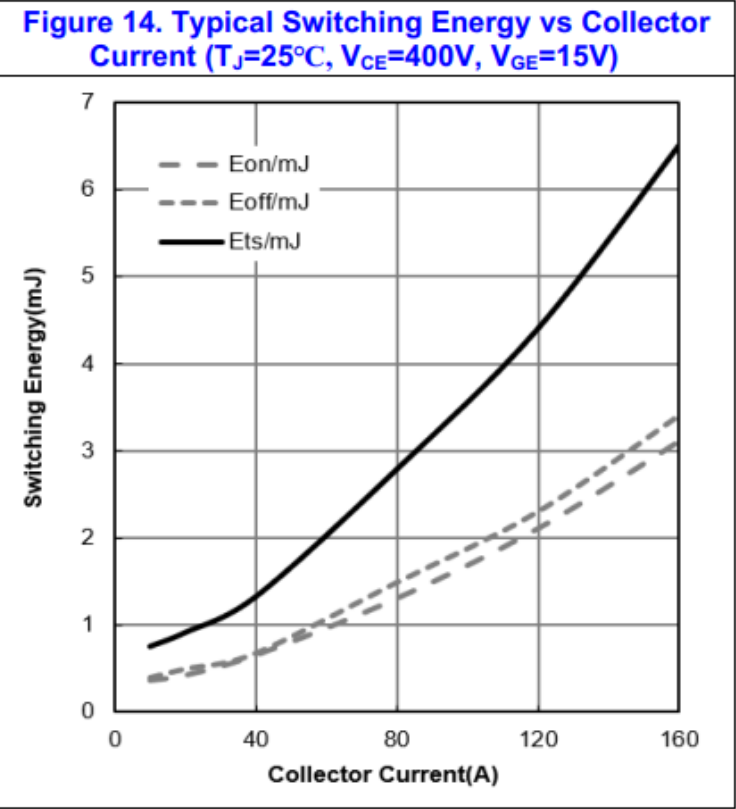
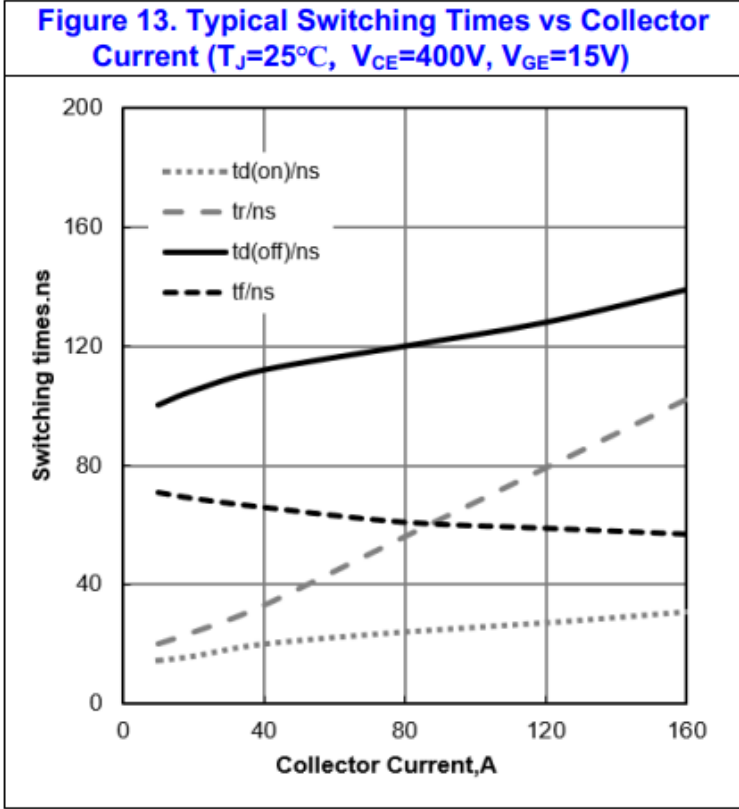
项目 Parameter	符号 Symbol	数值 Value	单位 Unit
结到管壳的热阻 (IGBT) Thermal Resistance, Junction to Case (IGBT)	Rth(j-c)	0.5	$^\circ C/W$
结到管壳的热阻 (Diode) Thermal Resistance, Junction to Case (Diode)	Rth(j-c)	0.8	$^\circ C/W$
结到环境的热阻 Thermal Resistance, Junction to Ambient	Rth(j-A)	40	$^\circ C/W$

特性曲线

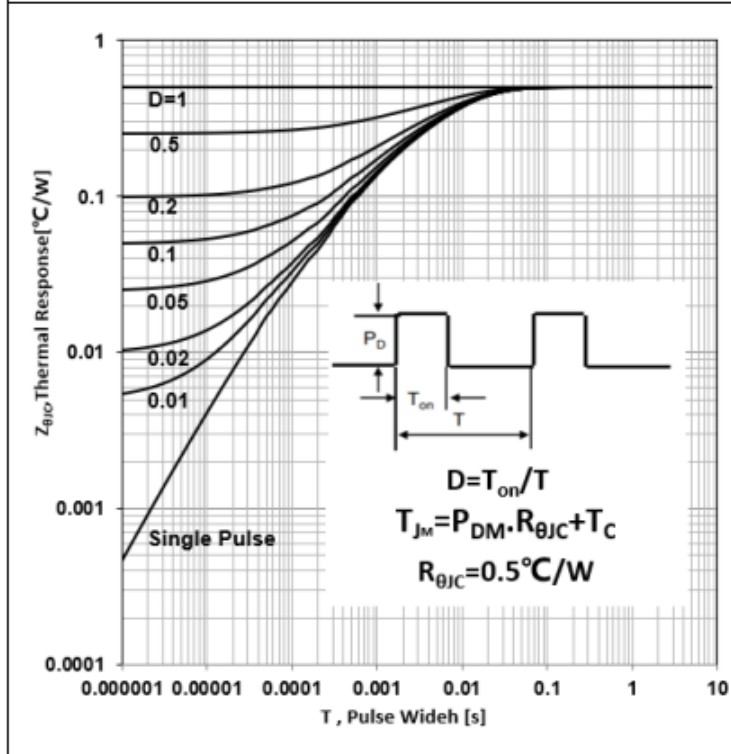
(ELECTRICAL CHARACTERISTICS (curves))



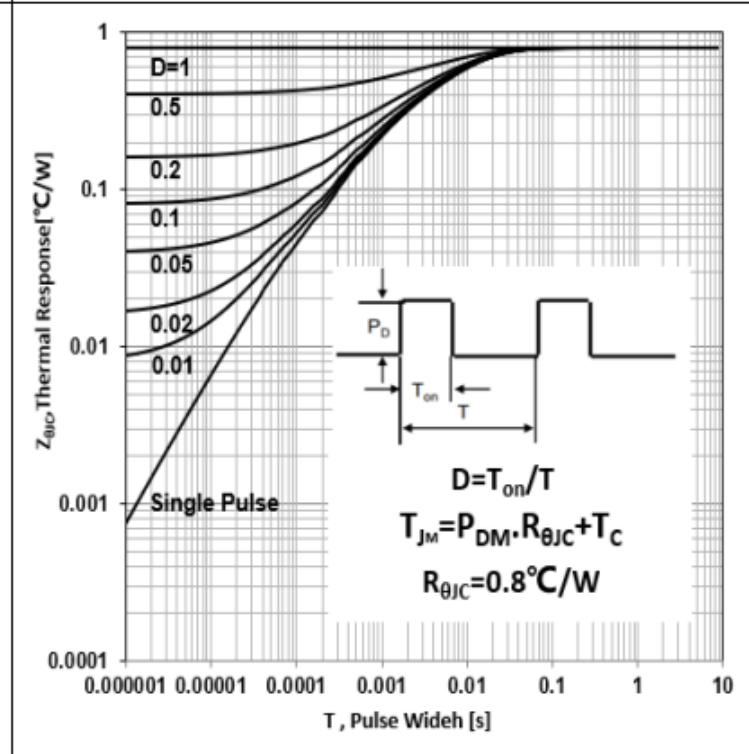




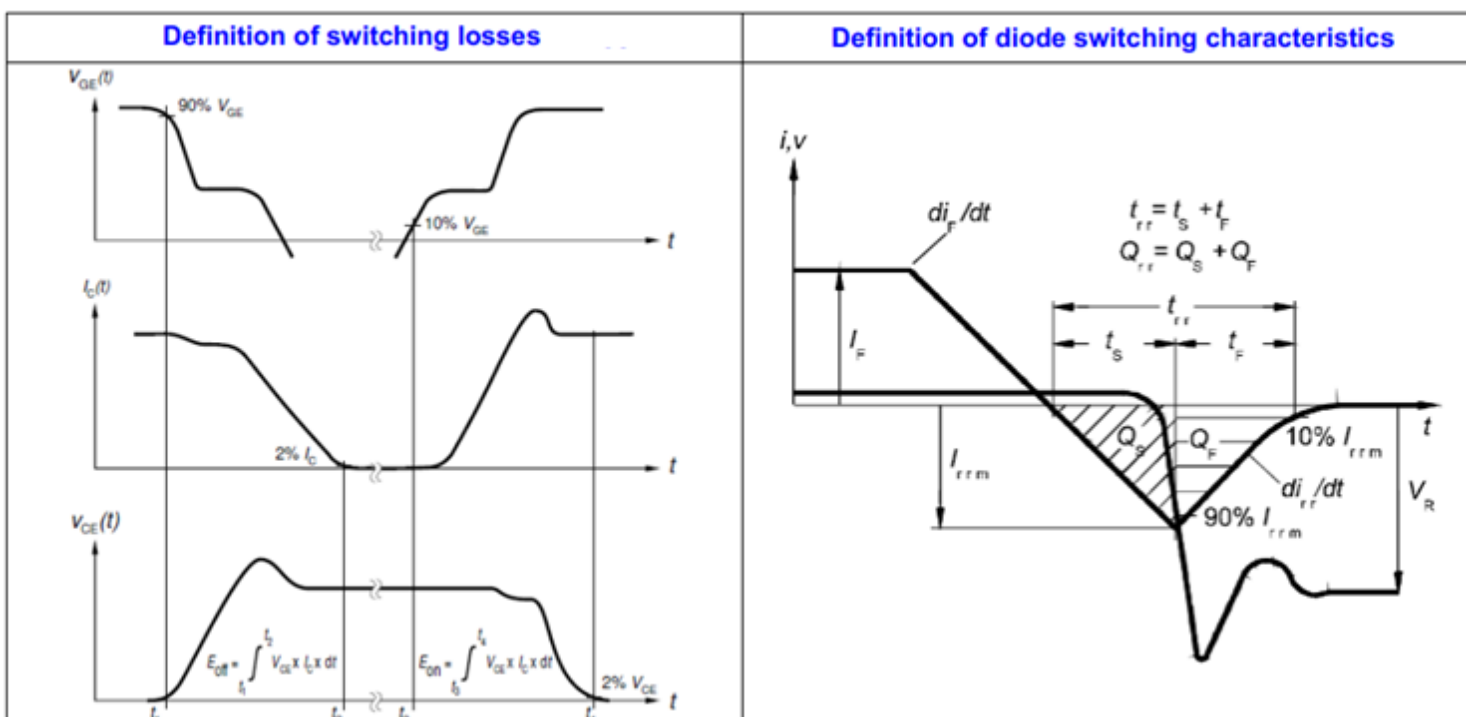
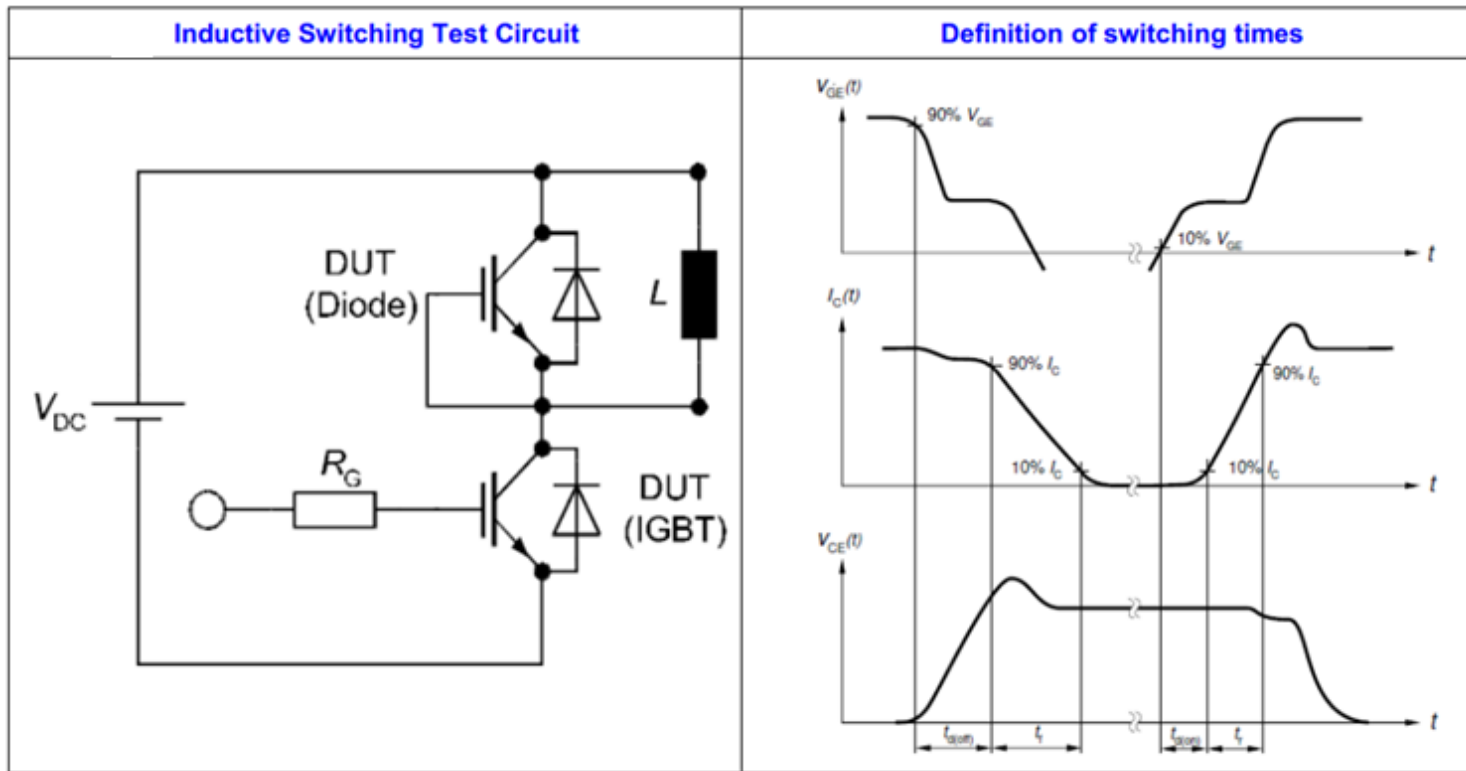
**Figure 19. IGBT Transient Thermal Impedance vs Pulse Width**



**Figure 20. IGBT Transient Thermal Impedance vs Pulse Width**

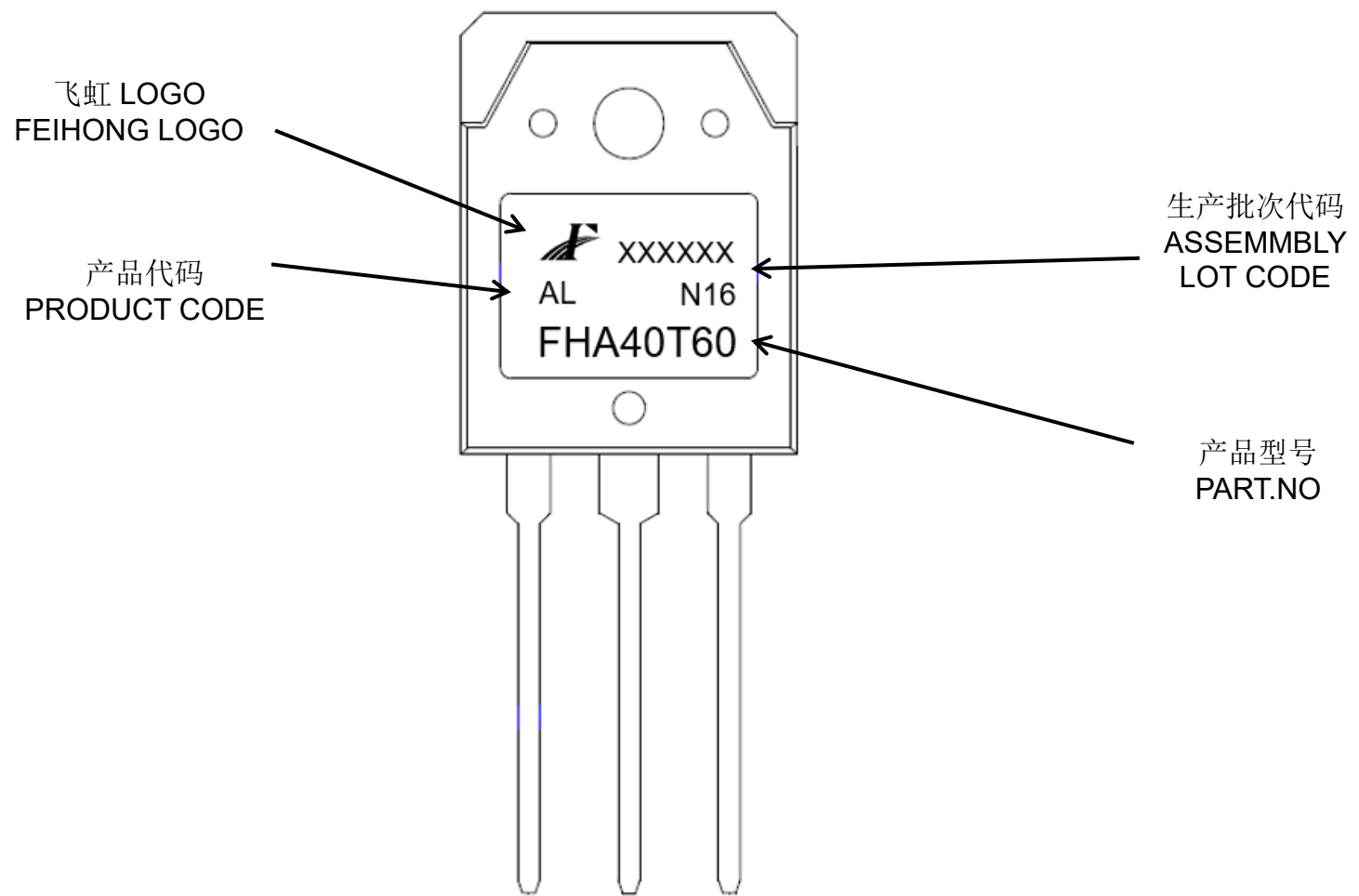


# Test Circuit and Waveform





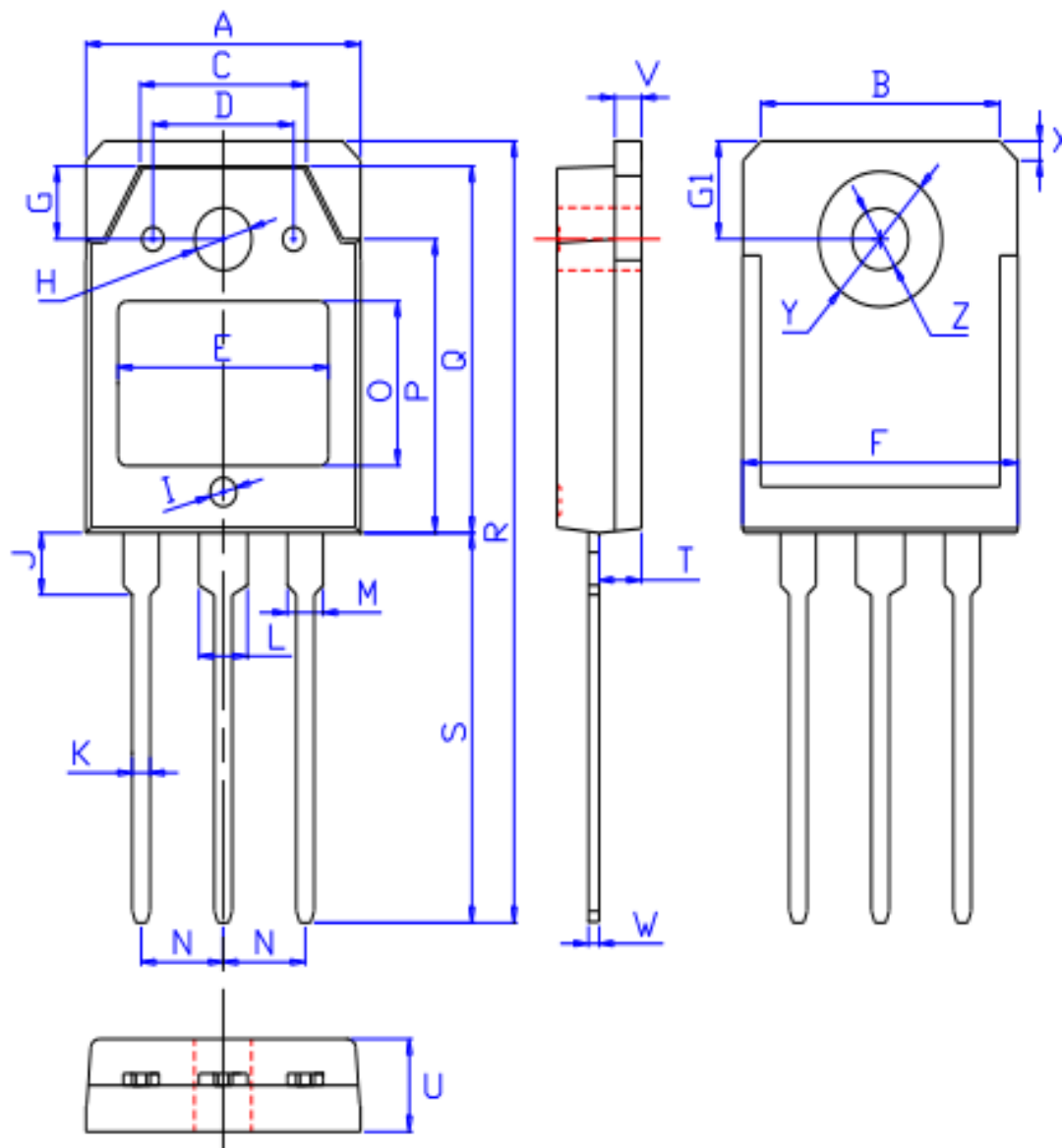
印记 Marking:



外形尺寸:

Package Dimension:

TO-3PN



DIM	MILLIMETERS
A	15.60±0.30
B	13.60±0.30
C	9.50±0.30
D	8.00±0.30
E	11.85±0.30
F	15.65±0.30
G	3.80±0.30
G1	5.00±0.30
H	φ 3.50±0.30
I	φ 1.50±0.30 深 0.15±0.15
J	3.20±0.30
K	1.00±0.15
L	3.10±0.15
M	2.10±0.15
N	5.45±0.30
O	8.40±0.30
P	13.90±0.30
Q	18.70±0.30
R	40.00±0.60
S	20.00±0.40
T	2.40±0.30
U	4.80±0.30
V	1.50±0.15
W	0.60±0.15
X	1.80±0.40
Y	7.00±0.30
Z	3.20±0.30

(Units: mm)