

A red line-art illustration of a hand, palm facing down, positioned above the title.

## PRODUCT DATA SHEET

A red line-art illustration of a hand, palm facing up, positioned below the title.

To learn more about JGSEMI, please visit our website at



**Datasheet**



**Resources**



**Samples**

Please note: Please check the JINGAO Semiconductor website to verify the updated device numbers. The most current and up-to-date ordering information can be found at [www.jg-semi.cn](http://www.jg-semi.cn). Please email any questions regarding the system integration to [JINGAO\\_questions@jgsemi.com](mailto:JINGAO_questions@jgsemi.com).

### ■ Features

- Collector-emitter voltage:  $V_{CE0} > 400V$
- Collector current-continuous:  $I_C = 300mA$
- Complementary to FZT558

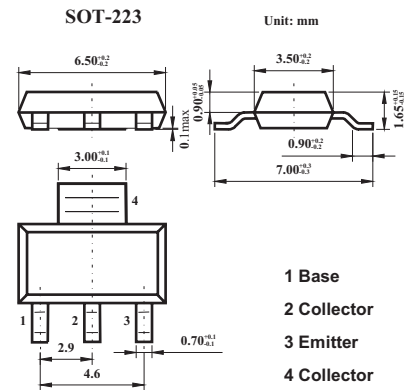

### ■ Absolute Maximum Ratings $T_a = 25^\circ C$

Parameter	Symbol	Rating	Unit
Collector-Base Voltage	$V_{CBO}$	400	V
Collector-Emitter Voltage	$V_{CEO}$	400	V
Emitter-Base Voltage	$V_{EBO}$	5	V
Continuous Collector Current	$I_C$	300	mA
Peak Pulse Current	$I_{CM}$	1	A
Base Current	$I_B$	200	mA
Power Dissipation at $T_{amb}=25^\circ C$	$P_{tot}$	2	W
Operating and Storage Temperature Range	$T_j; T_{stg}$	-55 to +150	$^\circ C$

**■ Electrical Characteristics Ta = 25°C**

Parameter	Symbol	Testconditons	Min	Max	Unit
Breakdown Voltages	$V_{(BR)CBO}$	$I_C=100\mu A$	400		V
Breakdown Voltages	$V_{CEO(sus)}$	$I_C=10mA^*$	400		V
Breakdown Voltages	$V_{(BR)EBO}$	$I_E=100\mu A$	5		V
Collector Cut-Off Currents	$I_{CBO}$	$V_{CB}=320V$		100	nA
	$I_{CES}$	$V_{CE}=320V$		100	nA
Emitter Cut-Off Current	$I_{EBO}$	$V_{EB}=4V$		100	nA
Emitter Saturation Voltages	$V_{CE(sat)}$	$I_C=20mA, I_B=2mA^*$		0.2	V
		$I_C=50mA, I_B=6mA^*$		0.5	V
	$V_{BE(sat)}$	$I_C=50mA, I_B=5mA^*$		0.9	V
Base-Emitter Turn On Voltage	$V_{BE(on)}$	$I_C=50mA, V_{CE}=10V^*$		0.9	V
Static Forward Current Transfer Ratio	$h_{FE}$	$I_C=1mA, V_{CE}=10V$	100		
		$I_C=50mA, V_{CE}=10V^*$	100	300	
		$I_C=100mA, V_{CE}=10V^*$	15		
Transition Frequency	$f_T$	$I_C=10mA, V_{CE}=20V, f=20MHz$			MHz
Collector-Base Breakdown Voltage	$C_{obo}$	$V_{CB}=20V, f=1MHz$		5	pF
Switching times	$t_{on}$	$I_C=50mA, V_{CC}=100V$	135 Typical		ns
	$t_{off}$	$I_{B1}=5mA, I_{B2}=-10mA$	2260 Typical		ns

\* Measured under pulsed conditions. Pulse width=300 $\mu$ s. Duty cycle  $\leq$  2%

## Attention

1, Any and all JGSEMI products described or contained herein do not have specifications that can handle applications that require extremely high levels of reliability, such as life-support systems, aircraft's control systems, or other applications whose failure can be reasonably expected to result in serious physical or material damage. Consult with your JGSEMI representative nearest you before using any JGSEMI products described or contained herein in such applications.

2, JGSEMI assumes no responsibility for equipment failures that result from using products at values that exceed, even momentarily, rated values (such as maximum ratings, operating condition ranges, or other parameters) listed in products specifications of any and all JGSEMI products described or contained herein.

3, Specifications of any and all JGSEMI products described or contained herein stipulate the performance, characteristics, and functions of the described products in the independent state, and are not guarantees of the performance, characteristics, and functions of the described products as mounted in the customer's products or equipment. To verify symptoms and states that cannot be evaluated in an independent device, the customer should always evaluate an d test devices mounted in the customer's products or equipment.

4, In the event that any or all JGSEMI products (including technical data, services) described or contained herein are controlled under any of applicable local export control laws and regulations, such products must not be exported without obtaining the export license from the authorities concerned in accordance with the above law.

5, No part of this publication may be reproduced or transmitted in any form or by any means, electronic or mechanical, including photocopying and recording, or any information storage or retrieval system, or otherwise, without the prior written permission of JGSEMI Semiconductor CO., LTD.

6, Any and all information described or contained herein are subject to change without notice due to product technology improvement, etc. When designing equipment, refer to the "Delivery Specification" for the JGSEMI product that you intend to use.